

ASD 531

Aspirating Smoke Detector

Technical description
as of firmware version 01.02.xx



Manufacturer:

Securiton AG
Alpenstrasse 20
3052 Zollikofen, Switzerland
www.securiton.ch

The product (hardware, software and technical documentation) is subject to the copyright of the manufacturer. Any prohibited modification, misuse, copying or prohibited sale of this product represents a violation of the copyright and will be legally prosecuted.

Copyright by Securiton AG

Validity



Notice

This document is valid only for the product described in this chapter and may be changed or withdrawn without prior notice. The validity of the statements made in this document applies until the statements are revised by a new edition of the document (T number with new index). The user of this document is responsible for staying up to date with its current status through the editor/publisher. We accept no responsibility for claims against any incorrect statements in this document that were unknown to the publisher at the time of publication. Handwritten changes and additions are invalid.

Foreign language documents as listed in this document are always released or changed at the same time as the German edition. If there are inconsistencies between the foreign language document and the German document, the German text is binding.

Some words in this document are highlighted in **blue**. These terms and designations are the same in all languages and are not translated. Users are encouraged to contact the editor/publisher if there are statements which are unintelligible, misleading, incorrect or which contain errors.

This document is intended for trained specialists for mounting, installation, commissioning and maintenance of the product.

This document is available in the following languages: German T 140 416 de
 English T 140 416 en

Current edition: Index b 30.04.2018 Po/ksa



Notice

The following document is applicable only to the ASD 531 aspirating smoke detector with the following production version and firmware version:

Production version	Firmware version
from 300418	from 01.02.xx

The validity of older production versions and firmware versions is guaranteed, with the exception of the new functionalities described in this edition. Additional information about the new functionalities can be found in the document history.

Other documents

Data sheet ASD 531	T 140 417	de / en
Material for the sampling pipe	T 131 194	multilingual (ED / FI)
Commissioning protocol	T 140 418	multilingual (EDFI)
Data sheets XLM 35	T 140 088	de / en / fr / it / es / pt / sv
RIM 36	T 140 364	de / en / fr / it / es / pt / sv
AFU 32 Aspirating Fan Unit mounting instructions	T 140 426	multilingual (EDFI)

Contents

1	General	9
1.1	Purpose	9
1.2	Safety and the environment	10
1.2.1	Notice and warning symbols	10
1.2.2	Safety information	10
1.2.3	Disposal	11
1.3	Uses and applications	11
1.4	Abbreviations and terms	11
1.5	Product identification	13
1.6	Guarantee	13
1.7	Product changes	14
1.8	Limitation	14
2	Function	15
2.1	General operating principle	15
2.2	Electrical functional principle	16
2.2.1	Power supply	16
2.2.2	Fan control	17
2.2.3	Microcontroller	17
2.2.4	Programming / operation	18
2.2.5	Displays	19
2.2.6	Relay	19
2.2.7	Outputs	20
2.2.8	Input	20
2.2.9	Interfaces	20
2.2.10	Airflow monitoring	21
2.2.11	Smoke sensor monitoring	21
2.2.12	Alarm release	21
2.2.12.1	Isolating the smoke sensor	21
2.2.13	Fault triggering	22
2.2.14	Event memory	22
2.2.15	Data logging on the SD memory card	22
2.2.16	Reset types	23
2.2.16.1	State reset	23
2.2.16.2	Hardware reset	23
2.2.16.3	Initial reset	23
2.2.17	Filter monitoring	24
3	Design	25
3.1	Mechanical	25
3.2	Electrical	27
3.3	Hardware / firmware	28
3.4	List of materials / components	29
3.5	Packaging	29

4	Planning	30
4.1	General aspects of planning	30
4.1.1	Standards, regulations, guidelines, approvals	30
4.2	Area of application	30
4.2.1	System limits	31
4.2.2	Usable accessory materials for the sampling pipe	31
4.3	Planning aids	32
4.3.1	Planning with "ASD PipeFlow" calculation	32
4.3.1.1	Values table for planning with "ASD PipeFlow"	33
4.3.2	Planning without "ASD PipeFlow" calculation	33
4.4	Space surveillance	34
4.4.1	Space surveillance applications	34
4.4.2	Principles of space surveillance	34
4.4.3	Types of sampling pipe layouts for space surveillance	35
4.4.4	System limits for space surveillance without "ASD PipeFlow" calculation	36
4.4.4.1	Detector sensitivity setting without "ASD PipeFlow" calculation	36
4.4.4.2	System limits for planning without "ASD PipeFlow" calculation	37
4.4.4.3	Sampling holes for planning without "ASD PipeFlow" calculation	37
4.4.4.4	Maintenance sampling hole	38
4.5	Equipment monitoring	39
4.5.1	Equipment monitoring applications	39
4.5.2	Principles of equipment monitoring	39
4.5.3	Examples of sampling pipe layouts for equipment monitoring	40
4.5.4	Sampling fixtures and sampling holes in equipment monitoring	40
4.6	Monitoring air-conditioning and ventilation ducts compliant with EN 54-27	41
4.7	Air recirculation	41
4.8	Settings	42
4.9	Electrical installation	43
4.9.1	Installation cable requirements	43
4.9.2	Determining the conductor cross-section	44
4.10	Restrictions	45
4.11	Environmental influences	46
4.12	Use compliant with UL 268, UL 268A and ULC-S529	46
5	Mounting	47
5.1	Mounting guidelines	47
5.2	Dimensioned drawing / drilling plan for the detector housing	47
5.3	Material for the sampling pipe	48
5.4	Mounting the detector housing	49
5.4.1	Opening and closing the detector housing	50
5.4.2	Mounting positions for the detector housing	51
5.4.3	Removing the air outlet pipe plug	52
5.4.4	Turning the labelling strip	52
5.5	Mounting the sampling pipe	53
5.5.1	General	53
5.5.2	Mounting with PVC tubes and fittings	53
5.5.3	Mounting with ABS tubes and fittings	53
5.5.4	Mounting with metal pipes and fittings	54
5.5.5	Linear expansion	54
5.5.6	Mounting the sampling pipe	55
5.5.7	Mounting for equipment monitoring	56
5.5.7.1	Screw-free fastening of the sampling pipe	56
5.5.7.2	Transition to a flexible tube	57
5.5.8	Creating the sampling holes	58
5.5.9	Mounting the sampling hole clips and maintenance clips	58
5.5.10	Mounting the sampling funnel	58
5.5.11	Mounting sampling stubs for a ceiling bushing	59
5.5.12	Mounting the filter-box, filter unit, dirt trap box, dust retaining box, water retaining box	60

6	Installation	61
6.1	Regulations	61
6.2	Cable entry	61
6.3	Deploying smoke sensors	62
6.4	Installing additional modules XLM 35, RIM 36	63
6.5	Electrical connection	64
6.5.1	Terminal assignment Main Board AMB 31	64
6.5.2	Terminal assignment for eXtended Line Module XLM 35	65
6.5.3	Terminal assignment for RIM 36 Relay Interface Module	65
6.6	Connection variants	66
6.6.1	Power supply	66
6.6.2	Reset input	66
6.6.3	Control	67
6.6.3.1	Control via voltage supply by means of auxiliary relay	67
6.6.3.2	Control via "Reset external" input	68
6.6.4	Connection to the FACP line	69
6.6.4.1	Connection to zone detection via AI / St relays	69
6.6.4.2	Connection to selective identification or addressable loop via AI / St relays	69
6.6.4.3	Connection to SecuriFire / Integral addressable loop from XLM 35	70
6.6.5	OC outputs	70
7	Commissioning	71
7.1	General	71
7.2	Programming	72
7.2.1	Configuration options	73
7.2.1.1	Smoke sensor alarm threshold	73
7.2.1.2	Air flow tolerance and delay time	73
7.2.1.3	Relay and state latching / RIM 36 relay assignment	73
7.3	Starting up	74
7.3.1	Commissioning procedure	74
7.3.2	Setting the alarm threshold without "ASD Pipeflow" calculation	74
7.3.3	Setting the alarm threshold with "ASD Pipeflow" calculation	75
7.3.4	Setting the air flow tolerance and delay time	75
7.3.5	Set date and time	76
7.3.6	Initial reset	76
7.3.7	Isolate device	76
7.3.8	Logging off additional modules XLM 35, RIM 36 and the SD memory card	77
7.3.9	Switch device inactive	77
7.4	Re-programming	78
7.4.1	Re-programming on the ASD 531	78
7.5	Download new firmware to the ASD 531	79
7.6	Measurements	80
7.6.1	Reading the airflow	80
7.7	Testing and checking	81
7.7.1	Checking the alarm release	81
7.7.2	Test triggerings	82
7.8	Filter monitoring operation	83
7.9	Commissioning protocol	84
8	Operation	85
8.1	Operation and display elements	85
8.2	Functional sequence of operation	86
8.3	Rotary switch "Mode" switch positions	86
8.4	Reset	87
8.5	Displays	87
8.5.1	Displays on the control unit	87
8.5.2	Indicators on the AMB 31 main board	88
8.5.3	SD memory card operation	88
8.5.3.1	Data logging on the SD memory card	88
8.5.4	Reading out the event memory	88
8.5.4.1	Interpretation of the event memory	88
8.5.4.2	Event groups	89
8.5.4.3	Event codes within event groups	89
8.5.5	Operation and displays on the XLM 35	91

9	Maintenance and service	92
9.1	General	92
9.2	Cleaning	92
9.3	Maintenance checks and function checks	93
9.3.1	Filter replacement on dust filter units	94
9.4	Replacing units	95
9.4.1	Replacing the smoke sensor	95
9.4.2	Replacing the aspirating fan unit	95
9.4.3	Replacing the air flow sensor	96
9.4.4	Replacing the AMB 31 Main Board	96
9.5	Disposal	97
9.5.1	Materials used	97
10	Faults	98
10.1	General	98
10.2	Warranty claims	98
10.3	Finding and rectifying faults	99
10.3.1	Fault states	99
11	Options	102
11.1	Sampling pipe	102
11.2	Use under extreme conditions	102
11.3	Use of detector boxes	102
12	Article numbers and spare parts	103
12.1	Detector housings and accessories	103
12.2	Sampling pipe and accessories	103
13	Technical data	104
14	List of figures	105
Document history		106

1 General

1.1 Purpose

The ASD 531 aspirating smoke detector has the task of continuously taking air samples via a sampling pipe tube network from a monitored area and feeding the samples to a smoke sensor. Thanks to this detection method and the product's excellent properties under severe ambient conditions, the ASD 531 aspirating smoke detector is used wherever problems are to be expected owing to poorly accessible monitored areas or latent disturbance variables during operation such that optimal protection can no longer be guaranteed with conventional point detectors.

The SSD 31 smoke sensor is used in the ASD 531. It has an alarm sensitivity range of 0.02%/m to 10%/m.

The ASD 531 aspirating smoke detector has two slots for additional modules. The following modules can be fitted:

- XLM 35 eXtended Line Module
- RIM 36 Relay Interface Module with 5 relays;

With the installation of a eXtended Line Module **XLM 35** the ASD 531 aspirating smoke detector can be ideally connected to the fire alarm systems SecuriFire (SecuriLine eXtended) and Integral (X-Line) via the addressable loop.

A further installation option is the **RIM 36** Relay Interface Module. This module enables the availability of all three pre-signal levels as well as the states of the smoke sensor and the sampling pipe.

The present technical description contains all information essential for trouble-free operation. For obvious reasons only those details specific to individual countries and companies or special applications can be discussed if they are of general interest.

1.2 Safety and the environment

Provided the product is deployed by trained and qualified personnel in accordance with this document, and provided the safety symbols all notices are observed, there is no danger to persons or property under normal conditions and when used properly. The product fulfils the requirements ensuring personal safety and environmental protection during operation. National and state-specific laws, regulations and directives must be observed and adhered to in all cases.

Observe these danger notices. They help prevent accidents and damage.

1.2.1 Notice and warning symbols

The following notice and warning symbols are used to draw attention to hazards and special properties.



Danger

The product may represent an immediate danger with a high level of risk to persons if the notice is not duly observed. If the danger is not avoided, death or serious injury may result.



Warning

The product may represent a possibly imminent danger with a medium level of risk to persons if the notice is not duly observed. If the danger is not avoided, death or serious injury may result.



Caution

The product may represent a possibly imminent danger with a low level of risk to persons if the notice is not duly observed. If the danger is not avoided, a minor injury may result.



Notice

If this notice is not observed, the product may malfunction, may cause property damage, or may be harmful to the environment.

1.2.2 Safety information



Read the user instructions

To ensure safe and proper use, it is absolutely necessary to read the instructions and other documentation accompanying the product before use and to keep such documentation at hand for later reference. It is imperative that the danger information in particular is observed.



Electrostatic discharge

The product includes electronic components that are sensitive to electrostatic discharge (ESD). Contact with persons or objects can cause an electrostatic discharge that damages or destroys the product. ESD bands for preventing electrostatic discharge are used for grounding persons and for equipotential bonding.



1.2.3 Disposal

Electrical and electronic devices and batteries

It is not permitted to dispose of electrical and electronic devices or batteries in the domestic rubbish. As the end user you are legally obliged to return them. Used electrical and electronic devices as well as batteries can be returned to the seller or taken to a designated recycling centre (e.g. a community collection point or dealer) at no cost.

Recycling

The product and its components including their packaging consist of recyclable material and can be disposed of for recycling purposes as described in this document.

1.3 Uses and applications

Thanks to the detection method, air sampling by means of a sampling pipe tube network and the good properties of the product under extreme ambient conditions, the ASD 531 aspirating smoke detector is used wherever problems can be expected owing to poorly accessible areas to be monitored or latent disturbance variables during operation such that optimal protection cannot be guaranteed with conventional point detectors. This includes:

- **Space surveillance:**
EDP rooms, ultra-clean rooms, warehouses, hollow floors, protection of cultural assets, transformer stations, prison cells, etc.
- **Equipment monitoring:**
EDP systems, electrical distributors, switch cabinets, etc.

The ASD 531 can also be deployed in areas where normally conventional point detectors are used. Local regulations and provisions must be observed from case to case.

The response behaviour of the ASD 531 has been tested in compliance with EN 54-20, Class A, B and C.

When control-unit-specific alarm transmitters, line monitoring elements etc. are used, the ASD 531 can be connected via its potential-free change-over contacts to all common fire alarm systems virtually without restrictions.

1.4 Abbreviations and terms

The following abbreviations and terms are used in this document: The abbreviations for tube material and accessories are listed in a separate document: T 131 194 (see also Sec. 5.3).

µC	= Microcontroller / microprocessor
ABS	= Acrylonitrile-butadiene styrene (plastic)
AFS 32	= Air Flow Sensor
AFU 32	= Aspirating Fan Unit
AI	= Alarm
AMB 31	= ASD main board
ASD	= Aspirating Smoke Detector
ASD PipeFlow	= Calculation software for the sampling pipe, "ASD PipeFlow" as of Version 2.3
BasiConfig	= Commissioning without the "ASD PipeFlow" calculation software
CE	= Communauté Européenne (European Community)
DA	= Detection area
Default	= Preset values / settings
DET	= Detector
DIN	= Deutsche Industrie Norm (German industry standard)
DZ	= Detection zone



General

Continuation:

EDP	= Electronic data processing
EEC	= European Economic Community
EEPROM	= Memory component for system data and ASD configuration
EMC	= Electromagnetic compatibility
EN 54	= European standards for fire alarm systems (DE = DIN, CH = SN, AT = Ö-Norm)
Ex-zone	= Area subject to explosion hazards
FACP	= Fire alarm control panel
FAS	= Fire alarm system
Fault	= Fault
Flash PROM	= Memory component for firmware
Flush mounting / surface mounting	= Flush mounted / surface mounted
FW	= Firmware
GND	= Supply ground (minus (-) pole)
H-AI	= Main alarm
HF	= High frequency
HW	= Hardware
IEC	= International Electrotechnical Commission
Initial reset	= First start-up on commissioning
IPS 35	= Insect Protection Screen
LED	= Light-emitting diode (indicator)
LS	= Airflow
LS-Ü	= Airflow monitoring
Manufacturer	= Securiton
OC	= Open collector output
OEM	= Original Equipment Manufacturer (reseller)
PA	= Polyamide (plastic)
PC	= Personal computer
PC	= Polycarbonate (plastic)
PE	= Polyethylene (plastic)
Pin	= Terminal pin
PMR 81	= Semi-conductor relay
Port	= Input or output component
PVC	= Polyvinyl chloride (plastic)
RAM	= Memory component
RIM 36	= Relay Interface Module
RoHS	= Restriction of Certain Hazardous Substances (eco-friendly manufacturing processes)
SecuriFire	= FAS system
SecuriLine	= Fire detector addressable loop
SecuriPro	= FAS system
SSD 31	= Smoke sensor
St	= Fault
St-LS	= Airflow fault
SW	= Software
Te.	= Terminal
UMS 35	= Universal Module Support
Update / Release	= Renewal / update of the firmware
V-AI	= Pre-alarm
VDC	= Direct current voltage
VdS	= VdS Schadenverhütung GmbH (DE) (association of indemnity insurers, Germany)
VKF	= Vereinigung Kantonaler Feuerversicherungen (cantonal fire insurance union, Switzerland)
VS	= Pre-signal
Watchdog	= Monitoring of the microcontroller
XLM 35	= eXtended Line Module

1.5 Product identification

For identification purposes, the ASD 531 and its units have rating plates or identification plates. The following product identifications apply:

Rating plate on the ASD 531 and identification on the packaging

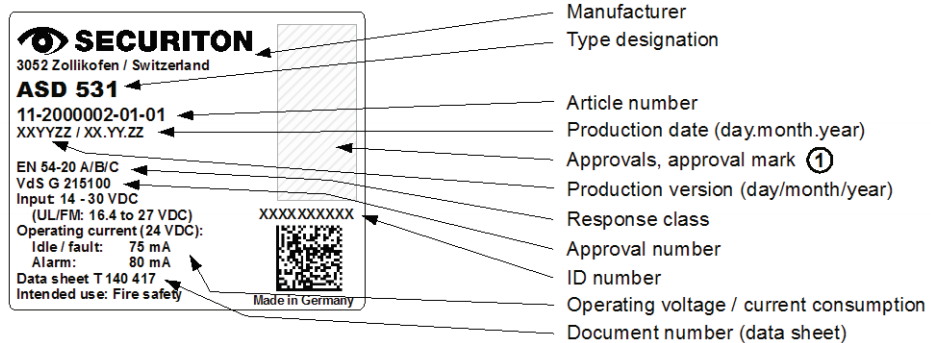

① Additional conformity marks may be affixed to a second rating plate or to an extended area of the rating plate (wider plate).

Identification on the packaging of the mounted printed circuit boards

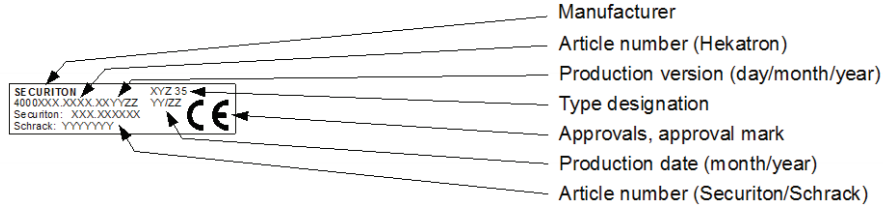

Notice

The rating plates, type designations and/or identifications on devices and printed circuit boards must not be removed, written over or defaced in any way.

Many products, such as accessories and mounting materials, are identified only with a sticker showing the article number. The manufacturer identifies these parts by article number.

1.6 Guarantee

Notice

The product may be operated only with the hardware, software and commissioning media designated and delivered by the manufacturer. Any unauthorised intervention in the hardware and/or software or the use of non-system products is prohibited and may result in malfunctions and/or damage to the product. If this is not observed, all guarantee and warranty rights with respect to the manufacturer of the product will become null and void. Further, non-observance of the user instructions as well as improper maintenance and repair work void the guarantee and product liability.

1.7 Product changes

The hardware is considered to comprise the complete detector housing and all the units belonging to the ASD 531 aspirating smoke detector such as sampling pipe and mounting material.

The firmware is located on the [Flash PROM](#) in the ASD 531. An EEPROM is fitted for storing and saving system-specific parameters.



Notices

- The ASD 531 is to be operated only with the appropriate original firmware from the manufacturer. Any unauthorised intervention in the firmware or the use of non-original firmware may result in malfunction and/or in damage to the device. Furthermore, all guarantee and warranty rights with respect to the manufacturer of the ASD 531 will become null and void as a result.
- We recommend always using the most recent SW version. In the event of changes by the manufacturer to the hardware or software of a product, there is no guaranteed update for existing systems.

1.8 Limitation



Notice

Only those smoke sensors in the device approval and in the list below may be used in the ASD 531 aspirating smoke detector. The use of third-party detectors voids the ASD 531 approval issued by the manufacturer.

The ASD 531 is fitted with the **SSD 31 smoke sensor** by the manufacturer. It has an alarm sensitivity range of 0.02%/m to 10%/m.

The response sensitivity of the smoke sensor can be adjusted within the range specified above. The value is defined via the AMB 31. This applies to applications with as well as without calculations using “ASD PipeFlow” (Sec. 4.3.1 and 4.3.2 respectively).

For use compliant with **UL 268** and **ULC-S529** the alarm sensitivity ranges must be configured as specified in Sec. 4.12.

2 Function

2.1 General operating principle

In the sampling pipe tube network, the fan generates a vacuum which results in fresh air continuously reaching the detector housing via the sampling pipe. In this way the smoke sensor is constantly supplied with new air samples from the monitored area. Should the smoke concentration exceed the permissible value, the ASD 531 triggers an alarm. The alarm is indicated visually on the ASD 531 and can be transmitted via a potential-free change-over contact to a superordinate fire alarm control panel.

The operational reliability of the aspirating smoke detector depends on the functional reliability of the smoke sensor and on the constant air supply to the system. A fan failure, blockage of the sampling holes or pipe breakage must be communicated to the fire alarm control panel in the form of a fault signal. This condition is satisfied by the airflow monitoring of the ASD 531.

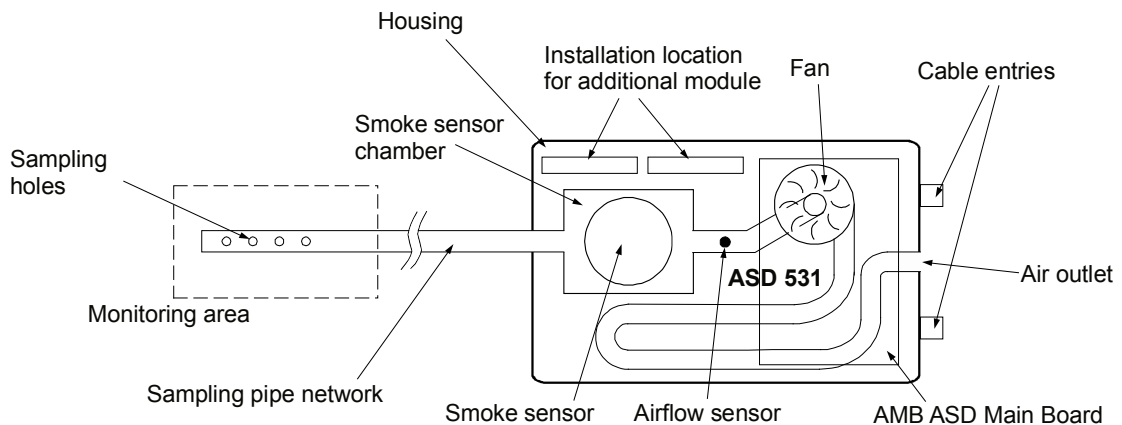

Fig. 1 General operating principle

2.2 Electrical functional principle

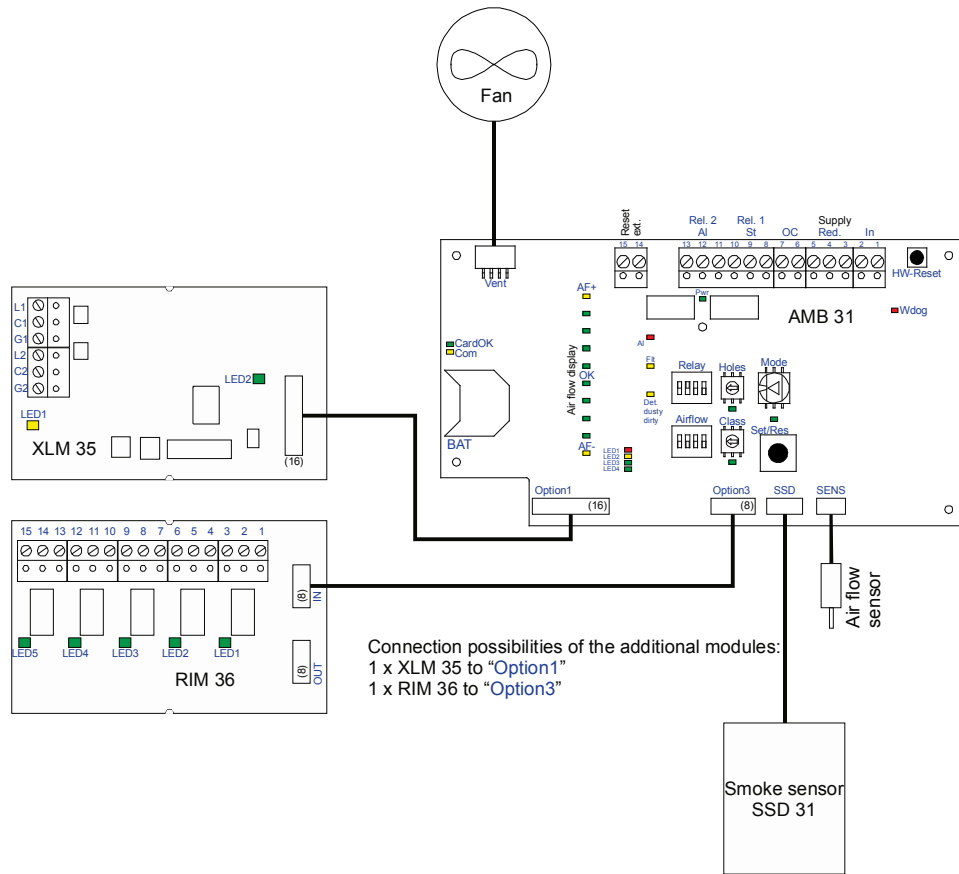

Fig. 2 Block diagram

2.2.1 Power supply

The operating voltage of the ASD 531 is +14 to +30 VDC (UL/FM = 16.4 to 27). On the AMB 31 Main Board, 5 VDC of the operating voltage is diverted for internal voltage use.

The operating voltage is monitored on the AMB 31 for undervoltage. If the operating voltage falls below 13.0 VDC (+0 / -0.3 VDC), the ASD 531 triggers an undervoltage fault.

2.2.2 Fan control

The physical and electrical properties of a fan cause a brief power surge when it is switched on and starts up, which in turn affects the conductor dimensioning and the total power consumption of the fire alarm system.

A specially designed circuit therefore ensures that the fan cannot exceed a specific maximum power consumption in its start-up phase. When the ASD 531 is switched on, the computer-controlled fan speed starts up slowly. After the fan has been powered up, the speed is kept constant.

Any blocking of the fan is detected by evaluating the motor speed. If the specified threshold is undershot, the fan supply is switched off and a fault is signalled.

The ASD 531 aspirating smoke detector has a constant, specified fan speed. The speed is **5250 rpm**.

2.2.3 Microcontroller

The entire program and switching sequence is controlled by a microcontroller. The firmware is stored on a **Flash PROM**. System-specific configurations are stored in an EEPROM.

The program is monitored by the internal watchdog of the microcontroller. In the event of a failure of the microcontroller circuit, an emergency fault is triggered. This is signalled on the device by the steady lit **Fault** LED. The "Fault" relay switches.

2.2.4 Programming / operation

The operation of the ASD 531 aspirating smoke detector in normal mode (after commissioning) is limited to switching on/off or to resetting a triggered event (alarm/fault). Operation is generally via the FACP, with input of the “Zone On/Off” and “Reset” functions (on “Reset external” input of the ASD 531).

Events triggered on the ASD 531 can be reset locally using the “Reset” key on the control unit or by briefly actuating the “Reset External” input. The reset is possible only if the triggered event is no longer pending (e.g. smoke sensor no longer has smoke). The application of a continuous signal at the “Reset external” input also deactivates (switches off) the ASD 531 (see also Sec. 2.2.8 and 6.6.2).



Notice

A local reset does not reset a higher-order FACP. It may happen that the reset in the ASD 531 triggers a fault in the superordinate line of the FACP.

To aid commissioning the ASD 531, there are three rotary switches and two DIP switches inside the device on the AMB 31 main board.

These elements are used when commissioning the ASD 531.

Fig. 3 shows the workflow for defining and programming project-specific device functions.

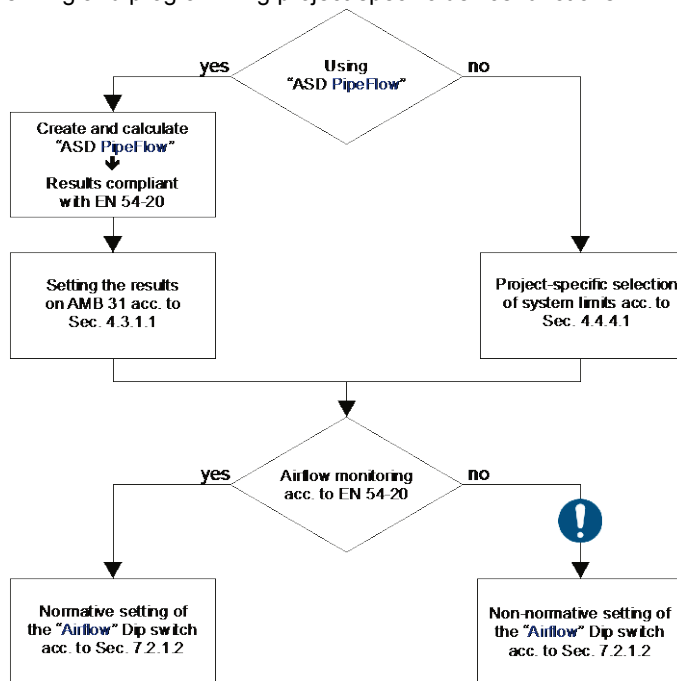

Fig. 3 Workflow for project-related programming



Notice

For normative systems the setting $\pm 20\%$ / 300 s is required. Other values are not EN tested and may be used only after consulting with the manufacturer.

The definitions of the pre-defined settings and the operator structure are found in Sec. 4.4.4.2, 7.2.1 and 8.3.

2.2.5 Displays

The following events are indicated by LEDs on the control unit:

- operation, fault, alarm, pre-signal 1 – pre-signal 3, detector dusty, detector dirty

Depending on the event, the LEDs are either continuously lit or flash at different frequencies (see Sec. 8.5).

2.2.6 Relay

The ASD 531 has several relays with potential-free change-over contacts with the following assignments (RIM 36 optional):

Unit	Relay designation	Function, events	
AMB 31	Rel. 1: ① Fault	Fault (all events) ASD inactive	
	Rel. 2: Alarm	Smoke sensor alarm release	
RIM 36 (from AMB 31)		Default assignment	Alternative assignment ②
	Rel. 1	Pre-signal 1	Alarm
	Rel. 2	Pre-signal 2	Alarm
	Rel. 3	Pre-signal 3	Alarm o fault ③
	Rel. 4	Smoke sensor: dust / dirt / fault	Alarm o fault ③
	Rel. 5	Sampling pipe: pipe blockage / pipe breakage / fan fault	Fault ③



Notices

- ① The "Fault" relay has picked up in the release state → contact Te. 10/8 closed, 10/9 open (ASD 531 under voltage; no fault event present).
- ② If you toggle "Relay" DIP switch 4 (ON position), the alternative relay assignment is in effect instead of the default relay assignment.
- ③ The following faults are included here:
 - ⇒ Smoke sensor; dust, dirt, fault
 - ⇒ Sampling pipe; pipe blockage, pipe breakage
 - ⇒ General; fan, initial reset, undervoltage, clock

Function

2.2.7 Outputs

There are two OC outputs (OC 1 and OC 2) on the ASD 531. Parallel indicators, feedback indicators or other consumers (relays) can be connected to these outputs. The outputs are configured with the following criteria (see also Sec. 6.6.5):

Unit	OC designation	Function, events
AMB 31	OC 1: Flt	Fault (all events) / ASD inactive
	OC 2: Al	Smoke sensor alarm release

2.2.8 Input

The ASD 531 has an “**External reset**” input used to reset the device to its normal state after an event. The input is potential-free (opto-isolator). It can be actuated both on the “plus” and on the “minus” side. The input operates in the 5 to 30 VDC range and has a pulse bandwidth of 0.5 to 10 s. When a continuous signal is applied for longer than 20 s, the ASD 531 is deactivated (fault state) (see also Sec. 6.6.2). Switching inactive via the “Reset external” input works only if the ASD 531 is not equipped with an XLM 35.

2.2.9 Interfaces

Depending on the installed additional modules, the ASD 531 has the following interfaces:

Unit	Designation	Function, events
AMB 31	SD memory card	Record operating data
		Update of the firmware
XLM 35	L1 / C1 / G1 // L2 / C2 / G2	SecuriFire / Integral addressable loop

2.2.10 Airflow monitoring

Airflow monitoring is based on the calorimetric measuring method (mass flow rate measuring method).

An air flow sensor is installed in the detector housing in such a way that any change in the sampling pipe (pipe breakage, pipe blockage) can be evaluated.

If there is an initial reset of the device and the sampling pipe is intact, the data of the airflow measurement is registered and saved as reference values (100%). The system sets the values in the middle of an electronically formed monitoring window. In the event of a shift in the values (actual values) out of the monitoring window ($\pm xx\%$) owing to pipe blockage or pipe breakage in the sampling pipe, the ASD 531 triggers an "airflow fault". The monitoring window can be set to different sizes on the ASD 531.

A variable delay time ensures that disturbance variables, e.g. air turbulence, are ignored. To handle fluctuations in the ambient temperature, the ASD 531 is equipped with a temperature compensation circuit.



Notice

A requirement for the correct operation of the airflow monitoring is that the airflow is logged when the ASD 531 is commissioned. With the triggering of an initial reset, the data is acquired and saved in the ASD 531 as reference values (see also Sec. 2.2.16, "Reset types").

According to **EN 54-20** a change in the airflow that is greater than $\pm 20\%$ must be reported as a fault. After the initial reset the airflow is displayed as 100% in the ASD 531 aspirating smoke detector when the sampling pipe is correct and clean. When all switches of the **Airflow** DIP switch are on **OFF**, any change in this value greater than $\pm 20\%$ – i.e. below 80% (dirt / pipe blockage) or above 120% (pipe breakage) – triggers an "airflow fault" after the **LS-Ü** delay time of **300 s** has expired.



Notice

For normative systems the setting $\pm 20\%$ / **300 s** is required. Other values are not EN tested and may be used only after consulting with the manufacturer.

2.2.11 Smoke sensor monitoring

The smoke sensor used on the ASD 531 is monitored on the AMB 31 Main Board. A failure of the sensor electronics, a dusty or dirty smoke sensor is registered as an event code and displayed as a state or fault (dust; only state display, fault triggering only via RIM 36). Likewise, the connection line between the smoke sensor and the AMB 31 is monitored and a fault is signalled if there is a failure.

To avoid false alarms, the SSD 531 smoke sensors used in the ASD 531 have a technical measure (TM) for comparing fire parameter pattern matching (measure for verifying the alarm state according to DIN VDE 0833-2).

2.2.12 Alarm release

The smoke sensor cyclically transmits its state as well as the signal amplitude / smoke level to the AMB 31 Main Board. The state of the smoke sensor is processed further on the AMB 31. If the set limits (alarm, pre-signal 1–3) are exceeded, the corresponding state "**Alarm**", "**Pre-signal 1–3**" is triggered on the ASD 531.

2.2.12.1 Isolating the smoke sensor

This function is used to place the ASD 531 in an isolated state using the "**Mode**" rotary switch. This means that test alarms can then be triggered on the ASD 531 without activating superordinate systems (FACP) (relays, OC outputs, XLM do not trigger). When the "Isolate" function is switched on, a fault is triggered on the ASD and forwarded to the superordinate centre. On the ASD the "**Fault**" LED is then continuously lit.

The "Isolate" state is also triggered when the "Filter replacement" procedure is activated (see Sec. 2.2.17 and 7.8).

2.2.13 Fault triggering

If a fault occurs on the ASD 531, the “Fault” relay is de-energised and the “Fault” display is activated. With the SD memory card, the fault profile can also be used in the event of a fault (see also Sec. 8.5.4.3 and 10.3.1). The following events trigger a fault (list is incomplete):

- Fault: airflow (after expiry of LS delay time)
- Fault: fan (fan limit data exceeded or fallen short of, tacho signal)
- Fault: initial reset
- Fault: smoke sensor dirty
- Fault: smoke sensor missing; communication disrupted; other
- AMB 31 communication fault to XLM 35 / RIM 36 (individual)
- Emergency fault (microcontroller failure)
- Undervoltage fault (13.0 VDC, +0 / –0.3 V)
- Fault: power supply (no voltage on the ASD, no “Fault” display)
- ASD inactive via “External reset” input.



Notice

The “Fault” relay has picked up in the release state → contact Te. 10/8 closed, 10/9 open (ASD 531 under voltage; no fault event present).

2.2.14 Event memory

The ASD 531 has an event memory capable of storing up to 1,000 events. The latest (i.e. most recent) event is always placed in the first position. If the memory exceeds 1,000 events, the oldest event is deleted. The event memory as a whole can be deleted only by the manufacturer. The event memory can be read out using an SD memory card.

2.2.15 Data logging on the SD memory card

Measurement values: All relevant measurement values are written to the SD memory card every second for each sensing tube and saved in **Log-Files** (*.xls file). After 28,800 entries (corresponding to 8 hours with an SD memory card interval of 1 s), a new **Log-File** is automatically generated. A total of 251 **Log-Files** (L000.xls to L250.xls) can be generated for long-term logging. After the last **Log-File** the oldest one (L000.xls) is overwritten. The 251 log files are sufficient to cover 83 days of data logging (with SD memory card interval of 1 s). The **log files** can be opened in Excel and the data processed with the diagram assistant to create charts.

Events: All events occurring in the ASD 531 are written to the **Event-Files** (*.aev file). After 64,000 events a new **Event-File** is created automatically. A total of 10 **Event-Files** (E000.aev to E009.aev) can be generated for long-term logging. After the last **Event-File** the oldest one (E000.aev) is overwritten. The 10 **Event-Files** are sufficient to log over 640,000 events. The **Event-Files** can be opened with a text editor. Please refer to Sec. 8.5.4 for the interpretation of the events.

2.2.16 Reset types

All events triggered on the ASD 531 go into latching mode whenever the default configurations are used. To reset, carry out a state reset.

The following reset types are possible (see Sec. 2.2.16.1 to 2.2.16.3).

2.2.16.1 State reset

A state reset is triggered by pressing the “Reset” key on the control unit or by actuating the “Reset external” input (see also Sec. 6.6.2). The state reset can be triggered only after an event, and only if the criterion that resulted in the event trigger is back in the normal state (e.g. smoke level in the smoke sensor is again below the trigger threshold or a fault event is rectified). As a result of the state reset, the ASD 531 continues to run “normally” and the fan does not stop.

2.2.16.2 Hardware reset

A hardware reset is triggered if there is a brief interruption in the supply voltage or if the “HW reset” key is briefly pressed on the AMB 31 (see also Fig. 41 and Fig. 45). This restarts the ASD 531. The fan stops and then slowly starts up again (start-up control). The previously programmed parameters of the ASD 531 are retained (system-specific configurations).



Notice

Attention: fire incident control, remote alerting!

A hardware reset briefly triggers the fault relay (approx. 1 s). Before maintenance work is carried out on the ASD 531, it is therefore essential to switch off the fire incident controls and remote alerting on superordinate systems (FACP).

2.2.16.3 Initial reset

An initial reset is triggered according to the information in Sec. 7.3.5.

An initial reset determines the basic data (e.g. connected sampling pipe, airflow data), which is then saved on the ASD 531. The airflow monitoring is also automatically adjusted. The basic data remains stored until such time as another initial reset is carried out. An initial reset does not discard the previously defined installation-specific parameters (system limits, response grade).



Notices

- During commissioning as well as after changes to the sampling pipe (length, repairs) or after changing the fan speed, it is **imperative** that an initial reset is carried out. An initial reset must also be carried out after repair work on the ASD 531 (replacement of air flow sensor, aspirating fan unit, AMB 31 main board).
- After an FW upgrade, an initial reset is required only if expressly mentioned in the relevant firmware description.
- When carrying out an initial reset, make sure the sampling pipe has been correctly implemented (sealed connecting points, sampling holes correctly drilled).
- If an initial reset has to be repeated because a triggered fault in the airflow monitoring cannot be reset, it should only be carried out if **all** the necessary measures for cleaning the sampling pipe have been implemented beforehand (including filter-box/filter unit, see also Sec. 9.3). If an initial reset is carried out with blocked or dirty sampling holes, there is the danger that insufficient or no air samples will be taken and hence the ASD 531 will no longer be able to trigger an alarm.
- Before carrying out an initial reset, allow the fan to run for a minimum of 2 min (after switching on or after making changes to the sampling pipe).

2.2.17 Filter monitoring

If a dust filter unit is installed in the sampling pipe, it can be monitored by means of connectible filter functions. The degree of soiling of the filter element is not monitored but rather the application-specific “filter service life” defined in the ASD. The filter service life is set to 6 months by default; it can, however, be parameterised system-specifically from 2 to 20 months (see Sec. 9.1 for setting in 2 month increments). After expiry of this filter service life, a “Filter fault (service life exceeded)” is triggered on the ASD. This fault trigger occurs only workdays at 10:00 a.m. (Monday to Friday, provided the time and date are correctly set) and can be reset once. After a waiting time of 14 days, another fault is triggered that can be reset only by replacing the filter element.

The “Filter replacement” function must be activated on the ASD in order to replace the filter element. The options for this are listed below. When filter replacement is activated, the aspirating smoke detector is set to the “Isolate” state. This insures that during the replacement work falling dust particles from the filter element do not cause a false alarm. After the filter has been replaced, the “Filter replacement” procedure is completed by pressing the “Reset” key on the ASD. This cancels the “Isolate” state and resets the fault on the ASD. “Filter service life” monitoring is restarted at 0.

The following filter monitoring operations are available on the ASD 531:

- Filter monitoring On/Off;
- Change filter service life (in months, 2 – 20);
- Read out filter service life (configured);
- Activate (start) filter replacement via *BasiConfig*;
- Activate (start) filter replacement by pressing the “Reset” key longer than 15 s (provided the filter monitoring is activated);
- Finish filter replacement by pressing the “Reset” key again.

3 Design

3.1 Mechanical

The ASD 531 aspirating smoke detector consists of the detector housing and a sampling pipe tube network. The sampling pipe is made of hard PVC or ABS tubes with an external diameter of 25 mm and an internal diameter of 20 mm (see also Sec. 5.3). In special applications – e.g. in extremely corrosive environments – other tube materials can also be used, subject to the specifications set out in Sec. 5.3. The sampling pipe has several sampling holes whose size is such that each hole extracts the same amount of air. The sampling pipe may be I-, U-, T-, H-, or E-shaped. The sampling pipe is symmetrically designed in principle. Asymmetrical sampling pipe tube networks can also be implemented with the help of the “ASD PipeFlow” calculation software.

The housing cover on the detector housing is opened by means of four rotary snap locks.

Integrated in the detector housing is a fan which, in conjunction with the sampling pipe, ensures an uninterrupted supply of air to the detector housing. Airflow monitoring detects any pipe blockages and pipe breakages in the sampling pipe.

There is one chamber for the smoke sensor in the detector housing. The air channel through the smoke sensor and fan are separated from the other parts inside the detector housing; this means the ASD 531 is able to remain fully operational during commissioning and maintenance work even when the housing cover is open.

The AMB 31 Main Board contains the processor-controlled evaluation electronics and the connection technology. There are two slots in the detector housing for installing optional additional modules (XLM 35, RIM 36).

Pre-defined labelling strips are used for labelling the control unit in the housing cover. If the device is mounted in a position rotated by 180°, the labelling strip can be turned accordingly.



Notice

The XLM 35 and RIM 36 additional modules are optionally available and are built into the ASD 531 when setting up the system. A maximum of two modules can be fitted.

Bottom part of detector housing

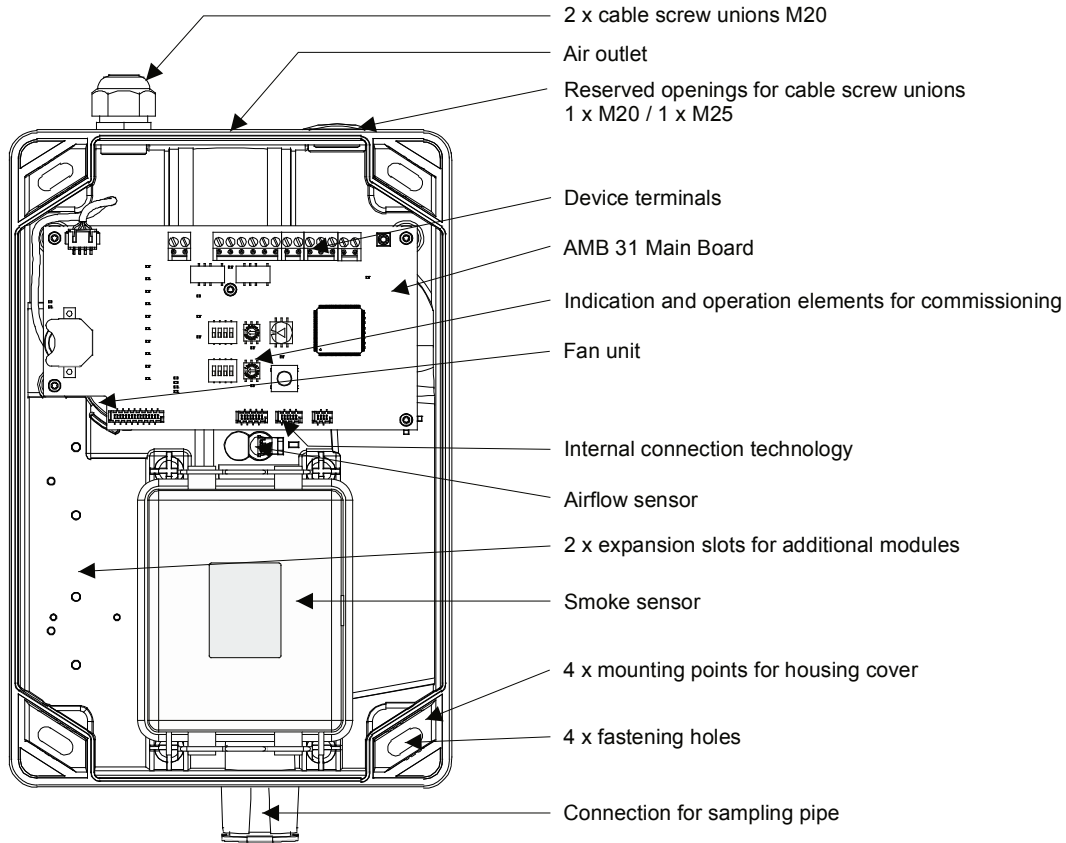

Housing cover

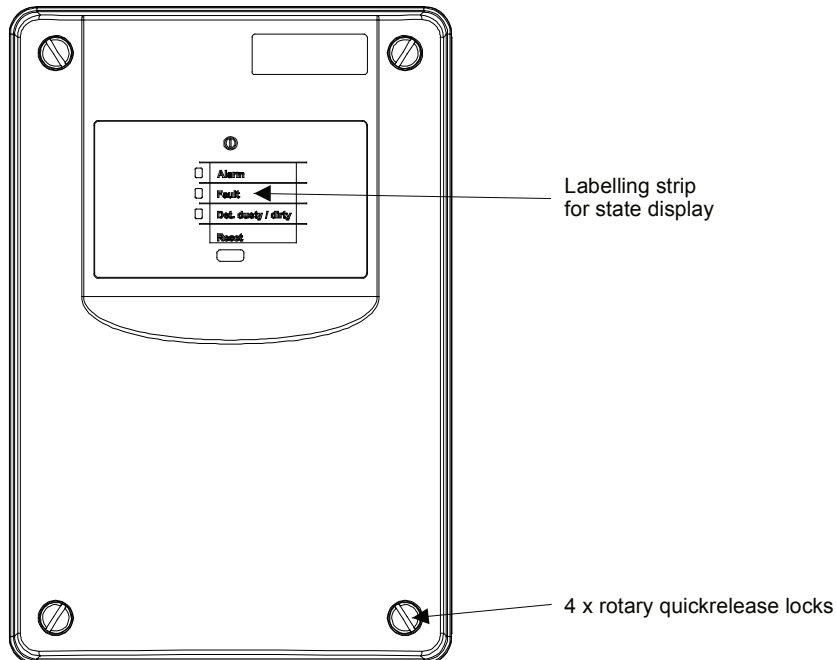

Fig. 4 Mechanical design

3.2 Electrical

The electrical design of the ASD 531 includes the following (may vary depending on the device version):

- AMB 31 Main Board
- Smoke sensor (SSD 31)
- Fan
- Air flow sensor
- Additional modules XLM 35, RIM 36.

The following circuit components and elements are on the AMB 31 Main Board:

- Power supply unit with switching controller
- Fan control with airflow evaluation and temperature measurement
- Smoke sensor evaluation
- Opto-isolator input for external reset
- Driver components for actuating the relays and open collector outputs
- Microcontroller with ports, RAM, Flash PROM, EEPROM, etc.
- Lithium battery
- RTC clock
- 3 rotary switches, 2 DIP switches and 3 LED displays for configuration setting
- 10 LEDs for airflow display
- 4 LEDs for displaying operation, alarm, fault, dust and dirt
- 2 relays with potential-free change-over contacts for fault, alarm
- Terminal blocks with pluggable screw terminals for the device connection
- LED for hardware watchdog
- SD memory card holder
- 2 LEDs for SD memory card signals
- 1 x 16-pin ribbon cable connector ([Option1](#)) for connecting to the XLM 35
- 1 x 8-pin ribbon cable connector ([Option3](#)) for connecting to the RIM 36
- One 6-pin ribbon cable connector for connecting to the smoke sensor
- One 4-pin plug for connecting to the air flow sensor
- HW reset button.

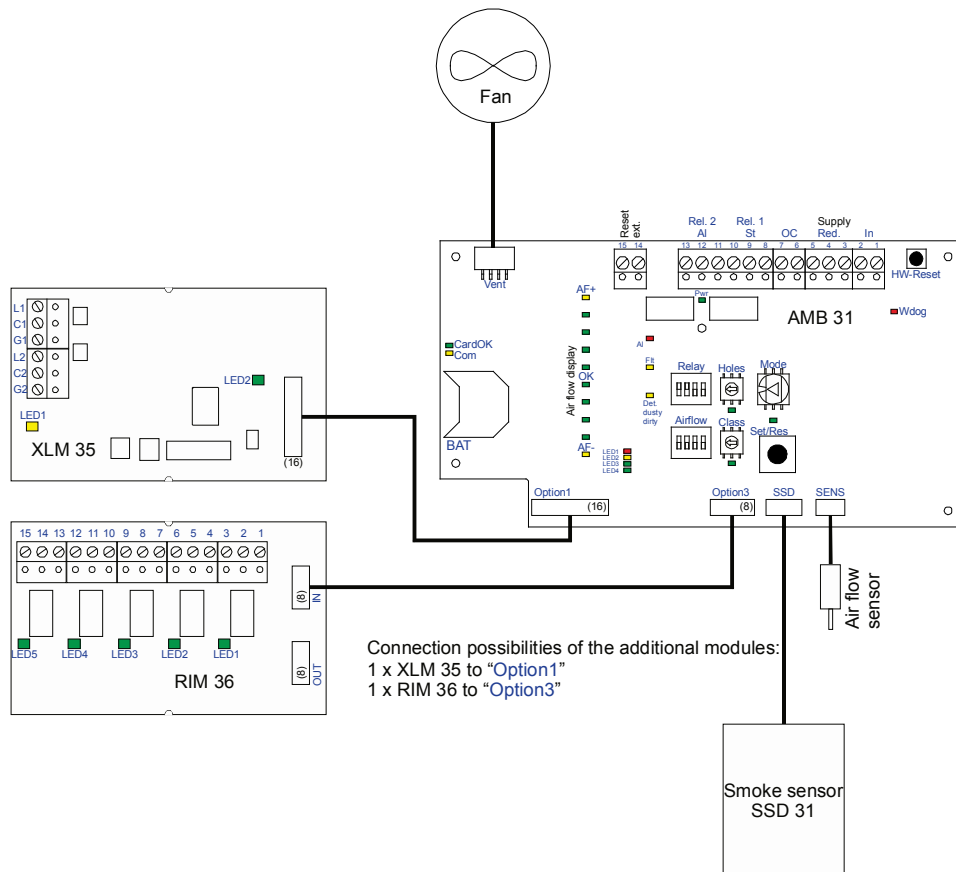

Fig. 5 Electrical design

3.3 Hardware / firmware

The hardware is considered to comprise the complete detector housing and all the units belonging to the ASD 531 aspirating smoke detector such as sampling pipe and mounting material.

The firmware is stored on the Flash PROM in the ASD 531. An EEPROM is fitted for storing and saving system-specific parameters.



Notices

- The ASD 531 is to be operated only with the appropriate original firmware from the manufacturer. Any unauthorised intervention on the firmware or the use of non-original firmware may result in malfunction and/or in damage to the device. Furthermore, all guarantee and warranty rights with respect to the manufacturer of the ASD 531 will become null and void as a result.
- We recommend always using the most recent SW version. In the event of changes by the manufacturer to the hardware or software of a product, there is no guaranteed update for existing systems.

3.4 List of materials / components

The ASD 531 **ships with** the following equipment (see also Sec. 5.1, 5.3, 9.5.1 and 12):

	AMB 31	Smoke sensor	Commissioning protocol	XLM / RIM
ASD 531	Yes	SSD 31	Yes	-- (accessories)
The mounting set comprises: 3 x company plates, 1 x M20 blind plug, 4 x S6 dowels, 4 x Torx wood screws (Ø 4.5 x 40 mm), 4 x M4 U-washers (Ø 4.3/12 x 1 mm)				

The following **accessory material** is available:

	XLM 35	RIM 36
ASD 531	1 x possible	1 x possible

The **material for the sampling pipe** can be purchased separately from the manufacturer in the required quantities, based on the size and use of the system. This material is listed separately in document **T 131 194** (see also Sec. 5.3, 9.5.1 and 12).



Notice

The material for the sampling pipe is a component of the VdS device approval. Only the materials listed and approved by the manufacturer may be used when setting up the system, see T 131 194. Materials from other sources may be used only if the manufacturer's written consent has been obtained.

A special **tool** is required for mounting and handling the ASD 531 (Torx screws). Please refer to the list in Sec. 5.1.

3.5 Packaging

The detector housing is delivered in a customised cardboard sleeve sealed with adhesive tape. The packaging is recyclable and can be reused.

The mounting set and installation material sundries are packed in recyclable bags. The sampling tube is supplied in sections (approx. 4–5 m). The flexible tube is supplied in 50 m rolls.

The contents of the packaging are specified as described in Sec. 1.5.



Notices

- Electronic components such as printed circuit boards are supplied in antistatic protective packaging. These components should be removed from the packaging just shortly before use or mounting.
- Only devices with unbroken or unopened seals (adhesive tape seal) are considered new. Packaging should not be opened until immediately before use.
- The cardboard packaging of the detector housing is can be stacked up to ten times its weight.
- The packages of the ASD 531 are suitable for post or rail shipment only to a limited extent.
- For transport in or to tropical regions, marine transport, etc., the appropriate measures must be taken (special packaging as provided by the shipper).

4 Planning

4.1 General aspects of planning

4.1.1 Standards, regulations, guidelines, approvals

Sec. 4 "Planning" below is a guideline for planning the ASD 531 aspirating smoke detector. These guidelines address the direct application only insofar as it applies to compliance with EN 54-20 and is required to ensure technically trouble-free operation.



Notices

- The use of special fire alarm systems such as the ASD 531 is subject in some cases to country-specific regulations and guidelines and must therefore be approved by the relevant technical bodies and authorities (insurance companies) prior to implementation.
- For many uses that are country, facility and application specific there are planning guidelines, application examples and applicable regulations and directives. These documents can be requested from the manufacturer of the ASD 531 system or from the responsible technical bodies and authorities.
- The country-specific regulations and guidelines apply as a matter of principle to the intended use, planning and application of the ASD 531 aspirating smoke detector. In any case the country-specific specifications always take precedence over the planning specifications outlined below.

The ASD 531 aspirating smoke detector complies with the requirements of European Standard EN 54-20, Class A to C. The following applies:

- EN 54-20, Class A high sensitive
- EN 54-20, Class B sensitive
- EN 54-20, Class C standard

4.2 Area of application

To comply with a required system configuration, the ASD 531 can be connected via its potential-free change-over contacts or by using control-panel-specific line modules (e.g. XLM 35) to all common fire alarm systems virtually without restrictions. The following factors determine which system configuration is best suited and should be used:

- Laws, regulations, guidelines
- Customer requirements;
- System type and area of application;
- Circumstances specific to the building
- New system, replacement of an existing system, expansion
- Cost/benefit ratio

4.2.1 System limits

The use of an ASD 531 aspirating smoke detector is subject to the system limits listed below and compliance with EN 54-20 requirements. Depending on the planning process, the system limits as set out in Sec. 0 **also** apply.

	Class A	Class B	Class C
Max. overall length of the sampling pipe tube network	75 m	75 m	75 m
Max. length from ASD to farthest sampling hole	40 m	40 m	40 m
Max. number of sampling holes	6	8	12

4.2.2 Usable accessory materials for the sampling pipe

Depending on the selected planning method – **with “ASD PipeFlow” calculation** according to Sec. 4.3.1 or **without “ASD PipeFlow” calculation** according to Sec. 4.3.2 – the following accessory materials can be used for the sampling pipe (a complete list of approved materials for the sampling pipe is provided in document T 131 194):

ASD 531		
	without “ASD PipeFlow”	with “ASD PipeFlow”
↳ Planning →		
↳ Configuration via →	<i>BasiConfig</i>	<i>BasiConfig</i>
Filter		
FBS 25 PC / FBL 25 PC	✓	✓
FBX 25 PC	✗	✗
DFU 535L / DFU 535XL / DFU 911	✓	✓
Capillary sampling tube		
TU 6 PVC	✗	✗
Heating accessories		
All heating accessories	✗	✗
Detonation flame arrester		
DFA 25-1 / DFA 25-2 / DFA 25-3	✗	✗
Automatic blow-out devices		
ADB 01A / ADB 02	✗	✓
Detector box		
REK 511	✗	✓

4.3 Planning aids

4.3.1 Planning with “ASD PipeFlow” calculation

The “ASD PipeFlow” calculation software is used for planning the sampling pipe tube network. Its purpose is to design on a drawing the pipe layouts required for implementing a system and assign the sampling holes. The “ASD PipeFlow” calculation software provides a selection of different tube materials, fittings and accessory parts (filter-boxes, water retaining boxes, etc.). The end result of the calculation software specifies the parameters required for a norm-compliant trigger in accordance with EN 54-20, Class A to C, after which the parameters are programmed on the ASD 531.

Asymmetrical sampling pipe tube networks can also be planned and set up using the “ASD PipeFlow” calculation software. System limits for EN 54-20 compliant triggering are defined in the calculation software.

The material stored in the “ASD PipeFlow” calculation software for the sampling pipe – and the “ASD PipeFlow” calculation software itself – are an integral part of the VdS device approval. A list of the available materials for the sampling pipe is provided in a separate document (T 131 194).

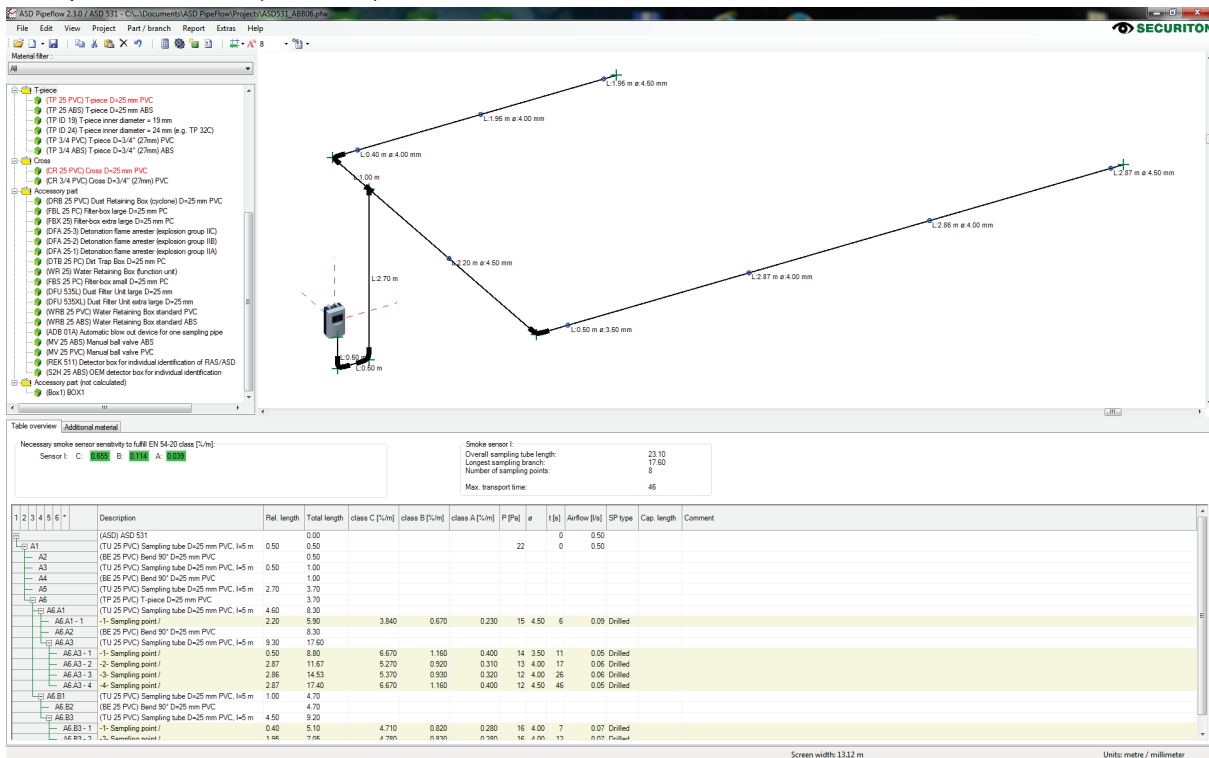

Fig. 6 “ASD PipeFlow” program interface



Notice about modernising existing systems with the ASD 531

When modernising existing systems (aspirating smoke detectors other than ASD 531), the existing sampling pipe tube network must be re-calculated using the “ASD PipeFlow” calculation software. The existing sampling pipe must be cleaned and checked (inspected for damage) prior to commissioning.

4.3.1.1 Values table for planning with “ASD PipeFlow”

After the calculation with “ASD PipeFlow”, the next more sensitivity value must be read from the table. Those on the AMB 31 must then be set accordingly.

		“Class” rotary switch Sensitivity range		
		1	2	3
“Holes” sensitivity rotary switch	1	10.000	1.202	0.144
	2	8.683	1.044	0.125
	3	7.539	0.906	0.109
	4	6.546	0.787	0.095
	5	5.684	0.683	0.082
	6	4.935	0.593	0.071
	7	4.285	0.515	0.062
	8	3.721	0.447	0.054
	9	3.231	0.388	0.047
	A	2.805	0.337	0.041
	B	2.436	0.293	0.035
	C	2.115	0.254	0.031
	D	1.836	0.221	0.027
	E	1.630	0.192	0.023
	F	1.384	0.166	0.020

4.3.2 Planning without “ASD PipeFlow” calculation

If planning is performed without “ASD PipeFlow”, a number of switch settings in the ASD 531 are saved with pre-defined values which are necessary for actuation in compliance with EN 54-20, Class A–C.

Notices: Planning without “ASD PipeFlow” calculation

- Sampling pipe networks are principally arranged symmetrically (including sampling holes). Any deviation in symmetry must not exceed $\pm 10\%$.
- The maximum tube lengths and number of sampling holes specified in Sec. 4.4.4.2 must not be exceeded.
- Only the tube materials listed in document T 131 194 with a diameter of 25 mm are to be used (including flexible hose).
- A **maximum of two 90° angles** may be used per sampling pipe. Any other changes of direction that may be necessary in the sampling pipe are to be implemented with 90° bends.
- A maximum of one filter-box (FBX) or one DFU 535XL resp. DFU 911 dust filter unit and one water retaining box (WRB) can be used in the tube network.
- When using other tube and accessory parts (e.g. more than two 90° angles, flexible tubes, dirt trap boxes), it is imperative that you use the “ASD PipeFlow” calculation software.
- The “ASD PipeFlow” calculation software must be used when planning equipment monitoring.
- The “ASD PipeFlow” calculation software must also be used in applications with air recirculation.

4.4 Space surveillance

4.4.1 Space surveillance applications

The ASD 531 aspirating smoke detector can also be used for the following applications:

- Spaces where point detectors are difficult to mount due to poor accessibility, e.g.:
 - cable galleries, cable tunnels, false ceilings, hollow floors
 - machine halls, production halls
 - low and high voltage rooms
 - computer rooms, clean rooms
- Spaces where, for aesthetic reasons, point detectors should not be mounted, e.g.:
 - Protection of cultural assets
 - Museums
- Spaces where point detectors could be damaged, e.g.:
 - Prison cells
 - public passageways
- Spaces with localised smoke development, e.g.:
 - warehouses with diesel forklifts
- Spaces with a high level of dust pollution and/or high atmospheric humidity.



Notice

Applications with a high level of dust and/or high atmospheric humidity require the use of accessory parts as recommended by the manufacturer, e.g.: Filter-box/filter unit, dirt trap box, water retaining box or three-way tap for sporadic cleaning of the sampling pipe with compressed air (see also Sec. 5.5.12).

4.4.2 Principles of space surveillance



Notices

The following principles apply to space monitoring:

- The number and arrangement of the ASD 531 units are based on the size of the space.
- In general the monitoring areas are the same as for point-type detectors. Directives that apply to specific objects – e.g. prison cells – must be observed.
- The sampling pipe tube networks are to be laid out in such a way that any anticipated fire is detected in its initial stages.
- The aspirating smoke detectors should be positioned in such a way that false alarms are avoided.
- When planning **without** “ASD PipeFlow” calculation, make sure the sampling pipe tube networks are laid out symmetrically (including sampling holes). Any deviation in symmetry must not exceed $\pm 10\%$.
- When planning **without** “ASD PipeFlow” calculation, the maximum tube lengths and number of sampling holes specified in Sec. 4.4.4.2 must **not** be exceeded.
- 90° bends are to be used instead of 90° angles for any changes in direction. An excessively high number of direction changes significantly affects detection time.
- When planning **without** “ASD PipeFlow” calculation, do not use more than **a maximum of two 90° angles** per sampling pipe. Any other changes of direction that may be necessary in the sampling pipe are to be implemented with 90° bends.
- The minimum sampling pipe length is **1 m** for all applications.
- Several rooms may be monitored by one and the same aspirating smoke detector only if so permitted by the relevant guideline (e.g. DIN VDE 0833-2 in Germany, VKF in Switzerland).
- For space surveillance involving premises with a height of more than 16 m, the situation must first be clarified beforehand with the manufacturer, the insurance companies and, if necessary, the fire brigade (in some cases larger or higher monitoring areas are possible).

4.4.3 Types of sampling pipe layouts for space surveillance

Typical layout types for space surveillance are I-shaped, U-shaped, T-shaped, H-shaped and E-shaped sampling pipe tube networks. Other sampling pipe layout designs can also be planned using the “ASD PipeFlow” calculation software.

When planning **with** “ASD PipeFlow” calculation, irregularly spaced sampling holes are also possible (Fig. 7).

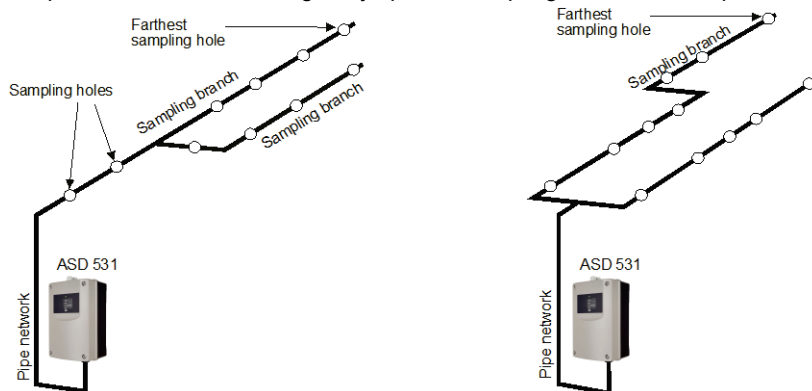

Fig. 7 Examples of planning with “ASD PipeFlow” calculation

If planning **without** “ASD PipeFlow” calculation, make sure the sampling pipe tube networks are set up symmetrically (max. symmetry deviation of $\pm 10\%$). This concerns tube layout as well as the spacing of sampling holes.

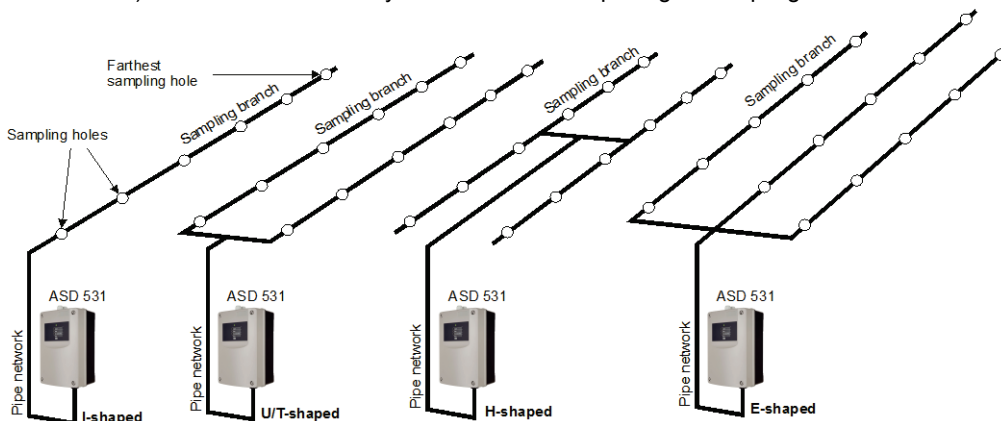

Fig. 8 Examples of planning without “ASD PipeFlow” calculation

4.4.4 System limits for space surveillance without “ASD PipeFlow” calculation

The settings specified in this section apply to planning without using the “ASD PipeFlow” calculation software. There are three switches to be set with the following meaning:

- Rotary switch “**Class**” and “**Holes**”, detector sensitivity;
- Dip switch “**Airflow**”, air flow tolerance and delay time.

Fig. 9 below illustrates the possible sampling pipe tube networks with definitions of tube length specifications. The maximum tube lengths and number of sampling holes can be found in the tables in Sec. 4.4.4.2, based on the response grades.

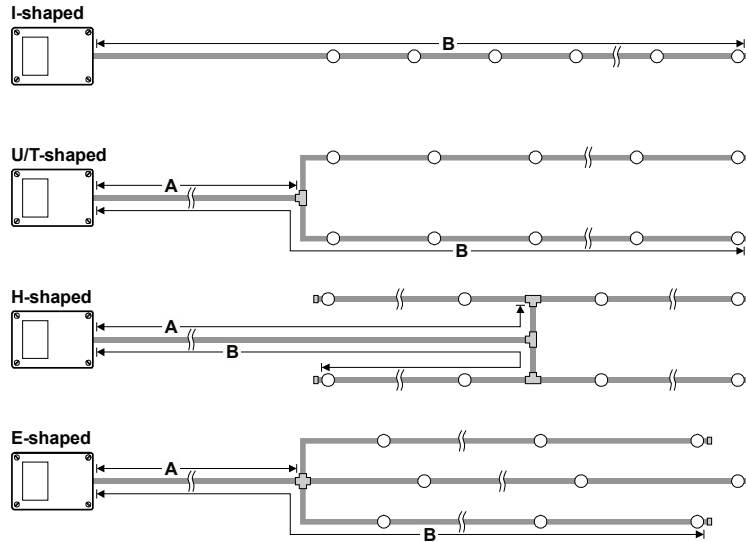

Fig. 9 Sampling pipe definitions

4.4.4.1 Detector sensitivity setting without “ASD PipeFlow” calculation

When planning without “ASD PipeFlow”, the positions **A** to **F** are used on rotary switch “**Class**”. If accessory materials as described in Sec. 4.2.2 and 4.3.2 are used in the sampling pipe, positions **A** to **C** are to be used for a response grade compliant with EN 54-20. For sampling pipes without accessory material, one of the positions from **D** to **F** is to be used when selecting the response grade compliant with EN 54-20. The rotary switch “**Holes**” sets the (total) number of sampling holes of the sampling pipe tube network.

Meaning of the rotary switch positions:

- | | |
|--|---|
| • Rotary switch “ Class ” position A , | EN 54-20, Class A (highly sensitive), with dust filter |
| • Rotary switch “ Class ” position B , | EN 54-20, Class B (sensitive), with dust filter |
| • Rotary switch “ Class ” position C , | EN 54-20, Class C (standard), with dust filter |
| • Rotary switch “ Class ” position D , | EN 54-20, Class A (highly sensitive), without dust filter |
| • Rotary switch “ Class ” position E , | EN 54-20, Class B (sensitive), without dust filter |
| • Rotary switch “ Class ” position F , | EN 54-20, Class C (standard), without dust filter |
| • Rotary switch “ Class ” position 1 to C | Number of sampling holes (A = 10; C = 12) |

4.4.4.2 System limits for planning without “ASD PipeFlow” calculation

Shape	Length from ASD to the last T-piece/cross (Fig. 9 “A”)	Max. length from ASD to farthest sampling hole (Fig. 9 “B”)	Number of sampling holes per sampling branch	Max. overall length of the sampling pipe
I	---	30 m	1 – 7	30 m
U / T	1 – 10 m	30 m	1 – 6	55 m
H	1 – 10 m	20 m	1 – 3	55 m
E	1 – 10 m	20 m	1 – 4	55 m

Notices

- The diameter of the sampling holes is specified in the tables in Sec. 4.4.4.3.
- Physically the sampling holes are to be spaced so that the resulting monitoring areas comply with country-specific guidelines.
- The overall length of the sampling pipe must not exceed the system limits as set out in Sec. 4.2.1.
- The filter-box / filter unit and water retaining box must always be mounted within the first 2 m of the ASD 531.

4.4.4.3 Sampling holes for planning without “ASD PipeFlow” calculation

To ensure that all the sampling holes take in the same amount of air, the diameter of the sampling hole on the sampling tubes fitted must increase as the distance from the detector housing increases.

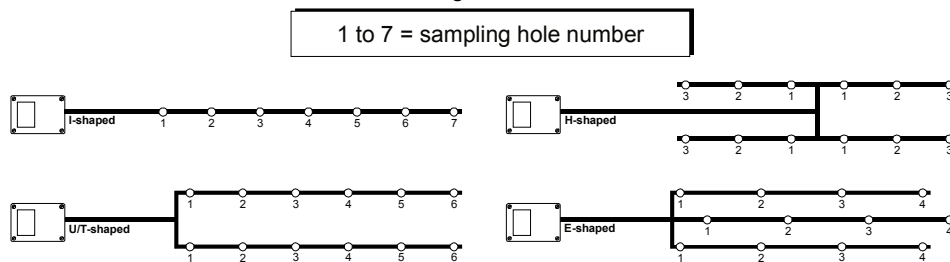

Fig. 10 Size of sampling holes

The tables below show the corresponding hole diameters for the numbers in Fig. 10 depending on the number of sampling holes per sampling branch.

If required, the sampling holes can be created using the special “sampling hole clips”. The sampling hole clips are available in various sizes (i.e. with hole diameters as indicated in the table above: 2.0 / 2.5 / 3.0 / 3.5 / 4.0 / 4.5 / 5 / 5.5 / 6 / 6.5 / 7 mm). See also Sec. 5.5.9.

I-shaped sampling pipes							
Number of sampling holes per sampling branch	Hole diameter in mm for the sampling hole number counted from the detector housing:						
	1	2	3	4	5	6	7
1	7.0						
2	5.5	7.0					
3	5.0	5.5	7.0				
4	4.5	4.5	5.5	7.0			
5	4.0	4.5	5.0	5.0	6.5		
6	3.5	3.5	3.5	3.5	4.0	5.5	
7	3.5	3.5	3.5	3.5	4.0	4.0	5.5

U/T-shaped sampling pipes						
Number of sampling holes per sampling branch	Hole diameter in mm for the sampling hole number counted from the detector housing:					
	1	2	3	4	5	6
1	7.0					
2	5.0	6.5				
3	4.5	5.0	7.0			
4	3.5	4.0	4.0	6.5		
5	3.0	3.0	3.0	3.0	5.5	
6	3.0	3.0	3.0	3.0	3.0	5.5

H-shaped sampling pipes			
Number of sampling holes per sampling branch	Hole diameter in mm for the sampling hole number counted from the detector housing:		
	1	2	3
1	7.0		
2	3.5	6.5	
3	2.5	2.5	6.5

E-shaped sampling pipes				
Number of sampling holes per sampling branch	Hole diameter in mm for the sampling hole number counted from the detector housing:			
	1	2	3	4
1	7.0			
2	4.5	7.0		
3	3.0	3.0	6.0	
4	2.5	2.5	2.5	6.0

4.4.4.4 Maintenance sampling hole

In applications with sampling holes that are difficult to access, a maintenance sampling hole can, if necessary, be made in the sampling pipe immediately after the detector housing. The maintenance sampling hole must be drilled with a hole diameter of 3.5 mm. The distance from the detector housing must be at least 0.5 m.

If required, the maintenance sampling hole can be made using the special “maintenance clip” (clip without drilling). See also Sec. 5.5.9.

Please note the following information:

Notices



When making a maintenance sampling hole, observe the following principles:

- A maintenance sampling hole should be made only if required, for example where normal sampling holes are difficult to access.
- A maintenance sampling hole is not included in the calculations set out in Sec. 4.4.4.2.
- The maintenance sampling hole is used only for maintenance purposes, to test the ASD 531 for alarming.
- In normal operation (no maintenance), the maintenance sampling hole must be sealed off with adhesive tape or a “maintenance clip” if available.
- All commissioning work on the airflow monitoring (initial reset) must be carried out with the maintenance sampling hole sealed off.

4.5 Equipment monitoring

4.5.1 Equipment monitoring applications

Equipment monitoring applications using the ASD 531 are additional monitoring applications to space surveillance. Equipment monitoring directly involves monitoring an object (machine, device or equipment). The following objects are typical examples of an ASD 531 monitoring:

- Electric cabinets with or without forced ventilation
- EDP computer systems and cabinets with or without ventilation
- Devices and machines in production technology
- Transmitting installations / transmission facilities
- Vacuum cupboards in the chemical industry (air recirculation), subject to prior consultation with the manufacturer.

4.5.2 Principles of equipment monitoring



Notices

Equipment monitoring is subject to the following principles:

- The country-specific application guidelines must always be adhered to.
- In equipment monitoring it is preferable to use Classes A and B compliant with EN 54-20.
- Equipment monitoring applications using the ASD 531 are additional monitoring applications to space surveillance.
- Planning with **the “ASD PipeFlow” calculation software is necessarily**. This guarantees optimal detection behaviour and ensures that the technical system limits are optimally utilised.
- Symmetry is not required for equipment monitoring.
- Unlike space monitoring, which involves individual sampling holes, equipment monitoring involves the use of **sampling fixtures** with several sampling holes.
- The **sampling fixture** is defined as a small pipe entity in the shape of an „I”, „U”, „T”, „H” or other form with typically 2 to 4 sampling holes.
- The sampling fixtures are arranged in such a way relative to the object that they intake the air outflow (ventilation slot or screen). Ideally the sampling holes are distributed symmetrically on each sampling fixture over the surface of the opening / screen.
- On objects with a high air-flow rate (strong ventilation), the sampling holes can be fitted with SF ABS sampling funnels for optimal smoke detection.
- The systems should be formed in such a way that false alarms are avoided.

4.5.3 Examples of sampling pipe layouts for equipment monitoring

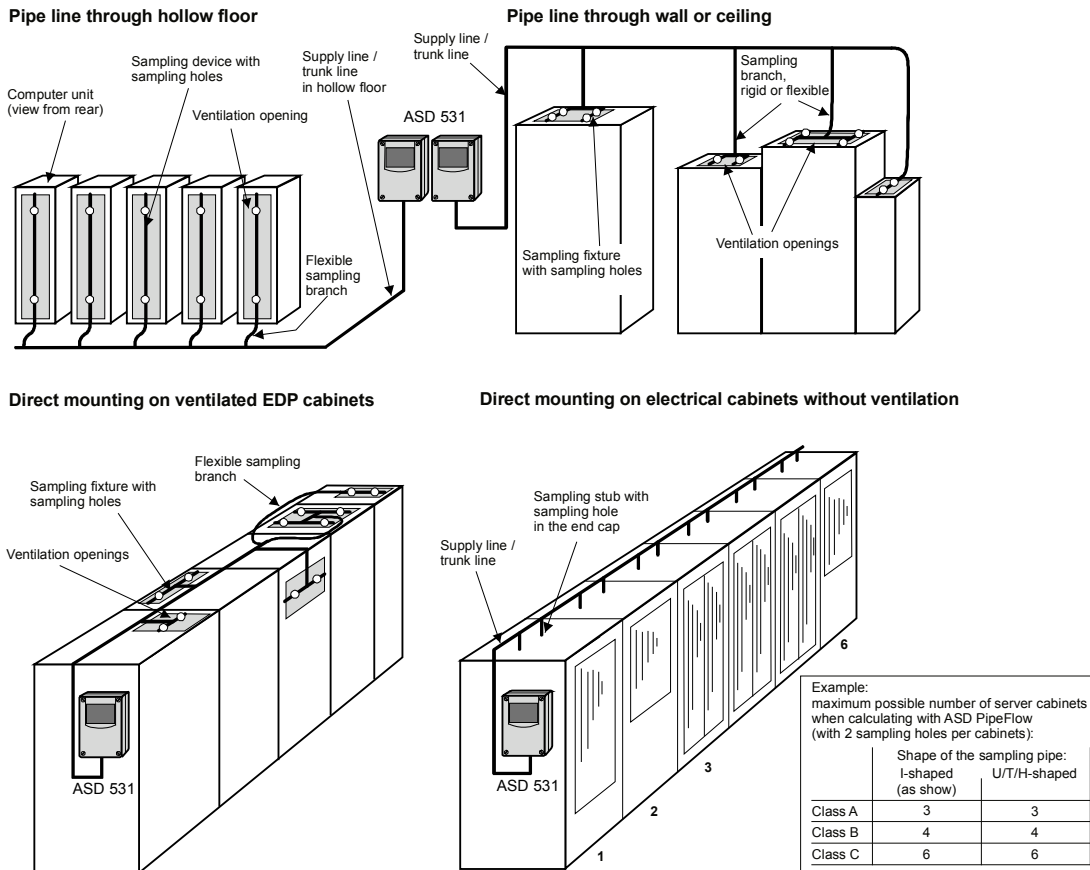

Fig. 11 Equipment monitoring layout variants (examples)

4.5.4 Sampling fixtures and sampling holes in equipment monitoring

The size and number of sampling holes in a sampling fixture are based on the size of the object's ventilation slot. The following approximate values apply:

Size of the ventilation slot (length x width in cm)	Shape of the sampling fixture	Number of sampling holes	Hole diameter (mm)
< 20 x < 15	I-shaped	2	according to "ASD PipeFlow" calculation
< 30 x < 15	I-shaped	3	
< 40 x < 15	I- or T-shaped	4	
< 80 x < 20	T-shaped	4	
< 40 x < 40	U-shaped	4	
> 40 x > 40	H-shaped	4	



Notices

- The sampling fixtures and their sampling holes must be placed directly in front of the object's airflow.
- The sampling holes must be facing the outflowing air.
- On objects with a high air-flow rate (strong ventilation), the sampling holes should be fitted with SF ABS sampling funnels for optimal smoke detection.
- Symmetry is not required for the sampling fixture.

4.6 Monitoring air-conditioning and ventilation ducts compliant with EN 54-27

For monitoring closed air-conditioning and ventilation ducts compliant with EN 54-27, the sampling pipe is installed directly in the duct and fastened to the two duct walls by means of a DF 25 ventilation duct flange. To ensure lasting functionality of the aspirating smoke detector in this application, it is obligatory that air recirculation from the aspirating smoke detector into the duct is implemented.

In so doing, the sampling pipe inside the duct must have the identical design for the sampling branch and blow-out branch (return conduit), i.e. the sampling holes of both branches are identical in number, size and orientation (facing the incoming air-flow). For optimal acquisition of the smoke particles, all sampling holes must also be fitted with SF ABS sampling funnels. For large ventilation ducts, monitoring in multiple levels may be necessary (e.g. "E-shape").

Notices

- The applicable standards and directives must be observed (e.g. DIN VDE 0833-2 and VdS 2095) when arranging the sampling pipes (location) in the air-conditioning and ventilation ducts.
- Area of application: 0 to 20 m/s, cross-section up to 4 m² (compliant with EN 54-27). After consulting with the manufacturer, channels with larger cross-sections and higher air velocities can also be monitored (outside EN 54-27).
- If air velocities greater than 15 m/s are possible in the air-conditioning and ventilation ducts, the initial reset must be performed at 15 m/s when commissioning the ASD.

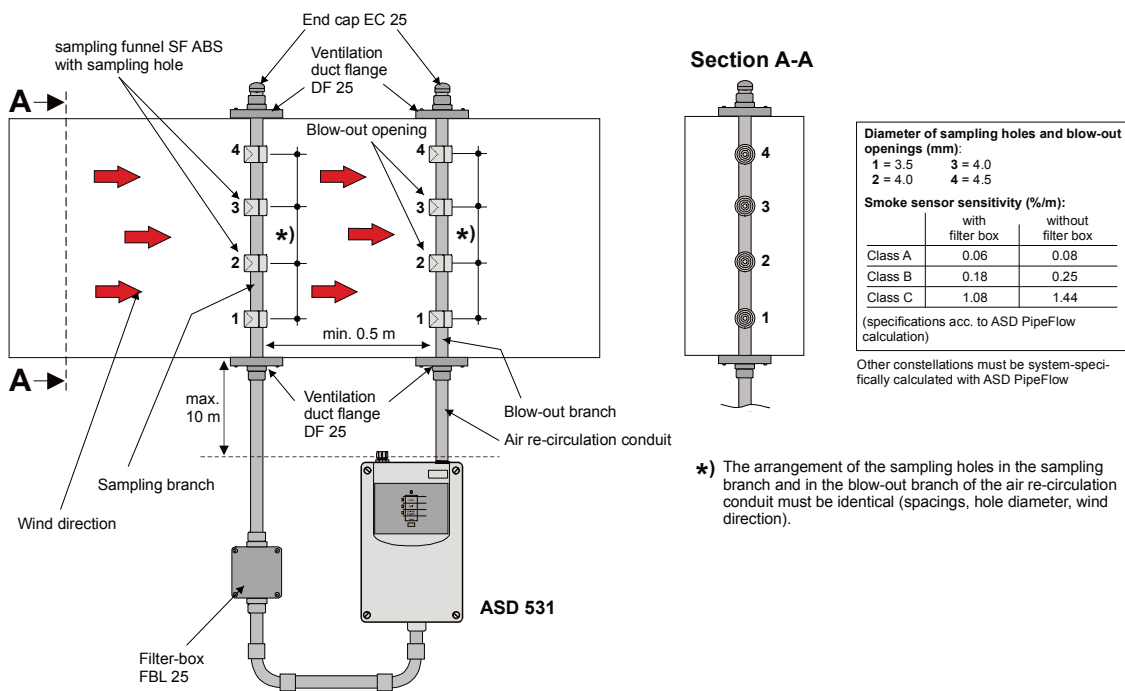

Fig. 12 Monitoring air-conditioning and ventilation ducts in compliance with EN 54-27

4.7 Air recirculation

In applications where the sampling holes and the detector housing are in different climate zones, the sampled air has to be re-circulated back to the climate zone of the sampling holes. It is imperative that the "ASD PipeFlow" calculation software is used to calculate the sampling pipe. The maximum length of the pipe for the air recirculation must not exceed 20 m from the detector housing.

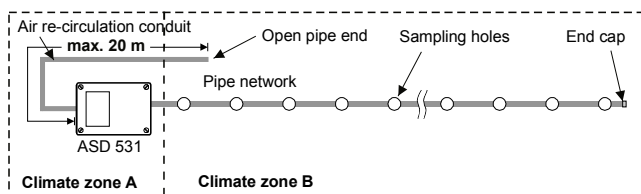

Fig. 13 Air recirculation for differing climate zones

4.8 Settings

Depending on the planning process – with or without the “ASD PipeFlow” calculation software – the following setting procedure is required:

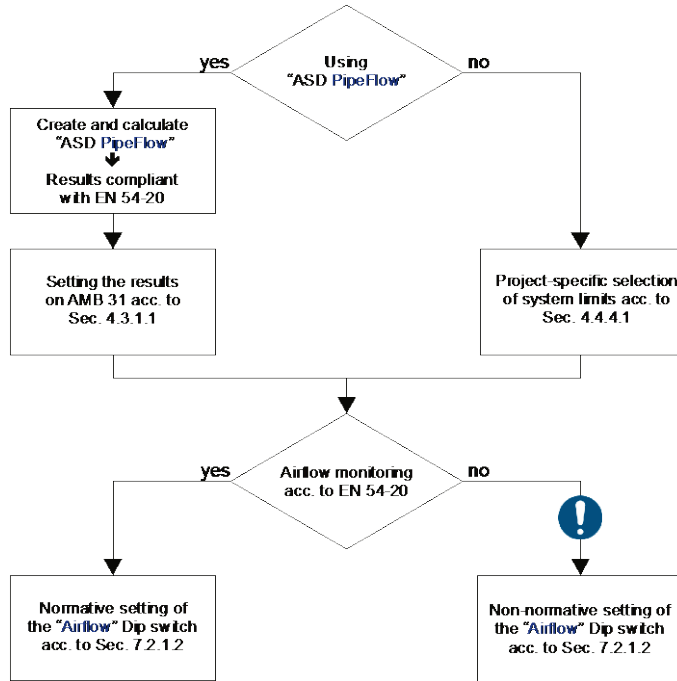

Fig. 14 Workflow for project-specific programming and adjustment

The definitions of the pre-defined settings and the operator structure are found in Sec. 4.4.4.2, 7.2.1 and 8.3.

Depending on the use of the ASD 531, it may be necessary to make adjustments to the airflow monitoring. These adjustments relate merely to the size of the monitoring window (pipe breakage/pipe blockage) and the fault delay time (time until the exceeded monitoring window is reported as a fault). Please note and adhere to the following information:

Notices

- For normative systems the setting **±20% / 300 s** is required. Other values are not EN tested and may be used only after consulting with the manufacturer.
- In applications with high levels of air turbulence, it may be necessary in some instances to increase the delay time and the window size to over **±20%**. **Important:** This means that norm EN 54-20 is no longer complied with and should only be used after consultation with the manufacturer.

4.9 Electrical installation

4.9.1 Installation cable requirements

The supply line from the FACP to the detector housing is defined by the line and FACP technology in use.

Cables with twisted pairs are to be used as a matter of principle. With 4-wire and multi-wire cables, twin- or quad-twist cables are to be used.

Laying the voltage supply line and line in parallel is permitted.

A separate wire pair is to be used for the ASD 531 voltage supply.

The electrical installation is usually performed with commercially available cables. Depending on the country of use, special fire detector cable may be required by the relevant authorities. The relevant country-specific authorities should therefore be consulted concerning the required cable types.

The installation cable must have a minimum wire diameter of 0.8 mm (0.5 mm²). **Please refer to Sec. 4.9.2 for determining the exact maximum cable length and the required cable cross-section.**



Notices

- For safety reasons (EN 54) individual cables must be used for the outbound and return lines for addressable loop technologies.
- Further, the **manufacturer's specifications for the FACP** concerning maximum **line length**, **cable type**, **shielding** etc. of the addressable loop technology **must be observed**.
- The order separation and installation type are also subject to country-specific guidelines and regulations.
- **Caution, use compliant with UL:** For system monitoring – for terminals “Alarm” and “Fault”, **do not use looped wire** under terminals. Break wire run to provide monitoring of connections.
- The electrical installation of the ASD 531 can normally be performed without screening. The installation of the SecuriFire / Integral addressable loop on an **XLM 35** must be **shielded**. Screening of the installation is required wherever EMC influences are to be expected. In the following environments disturbance variables can be expected and the installation must be provided with screening accordingly:
 - In and around transmitter and radio facilities. Near high-voltage and low-voltage installations with high energy. In areas with EMC field intensities in excess of 10 V/m. In cable ducts and vertical shafts together with high-energy cables. In areas with high-energy devices and installations (generators, power plants, railway facilities, X-ray equipment, etc.). Outside buildings.
- If screening is used, the cable screening in the ASD 531 is to be connected to an additional support terminal. The cable screening must **not** be connected to the minus or **ground** terminal of the AMB 31.

4.9.2 Determining the conductor cross-section



Notices

- The conductor cross-section must always be determined and logged accordingly. Insufficiently rated conductor cross-sections can result in malfunctions of the aspirating smoke detector.
- When determining the required conductor cross-section, it is necessary to take into consideration not only the ASD 531 power consumption but also the limit data of the line and FACP technology used.
- As a rule, the conductor cross-section required for the ASD supply is also sufficient for the line. It is nevertheless advisable to calculate the minimum line cross-section with the FACP-specific limit data (power consumption/voltage drop).
- The terminals of the ASD 531 are designed for maximum 2.5 mm². To feed the supply line on to a neighbouring ASD it may therefore be necessary to install additional distributor or support terminals. **Important:** these support terminals may be used only for the power supply line and not for the alarm line.
- The current consumption of consumers operated on the OC outputs must be taken into account when the current is calculated.

To ensure the ASD 531 is able to operate fault-free, the conductor cross-section must be rated so that the maximum required power consumption is available in all cases at the end of the electric installation (i.e. at the ASD 531).

When determining the conductor cross-section, the highest possible power consumption by the ASD 531 during normal operation (after switching on) is the decisive factor. Due to its circuitry design, the ASD 531 has the highest power consumption at the minimum supply voltage, i.e. at 14 VDC.

Below are the decisive conductor cross-section values of the ASD 531 (measured at peak fan speed):

- Minimum wire diameter: 0.8 mm (0.5 mm²)
- Maximum current consumption at:
 - ASD 531, ASD in alarm 14 VDC
 - Additionally with RIM 36 120 mA
 - Additionally with XLM 35 30 mA
 - Additionally with XLM 35 15 mA
- Maximum permitted voltage drop on the installation: 10 VDC

Calculation: $A = \frac{I \times L \times 2}{\gamma \times \Delta U}$ $I =$ Power consumption (in A) $L =$ Single line length (in m)
 $2 =$ Factor for return line $\gamma =$ Cu conductivity (57)
 $\Delta U =$ Voltage drop (in V)

Example 1, ASD 531, line length 500 m:

Calculation: $A = \frac{0.120 \times 500 \times 2}{57 \times 10} = 0.21 \text{ mm}^2 \rightarrow \mathbf{0.5 \text{ mm}^2}$

Example 2, ASD 531 with XLM 35, line length 400 m:

Calculation: $A = \frac{0.135 \times 400 \times 2}{57 \times 10} = 0.19 \text{ mm}^2 \rightarrow \mathbf{0.5 \text{ mm}^2}$

4.10 Restrictions



Notices

The following restrictions apply to the use and application of the ASD 531. For other solutions, please consult the manufacturer.

General information and space surveillance:

- The sampling holes of the tube network and the detector housing must be in the same climate zone (pressure/temperature zone) (sampled air may have to be recirculated to the other climate zone). Pressure differences between detector housing and sampling pipe (sampling holes) are not permitted.
- If sampling pipes with air at room temperature have to be routed through areas in which the temperature may drop below 4°C, the tube parts in these areas may have to be specially installed (possibly by isolating the sampling pipe as specified by the manufacturer).
- Applications with a high level of dust and/or high atmospheric humidity require the use of accessory parts as recommended by the manufacturer, e.g.: Filter-box/filter unit, dirt trap box, water retaining box or manual ball valve for sporadic cleaning of the sampling pipe using compressed air (see also Sec. 11).
- The maximum pipe length specified must **not** be exceeded.
- Several rooms may only be monitored by one and the same aspirating smoke detector if so permitted by the relevant guideline (e.g. DIN VDE 0833-2 in Germany, VKF Cantonal Fire Insurance Union in Switzerland).
- In the event of an emergency the sampling holes must be accessible for cleaning (possibly by cleaning using compressed air from the detector housing or under 0°C with nitrogen).
- The fan creates a sound pressure level (possibly mount the detector housing in an acoustically insulated cabinet – e.g. ASD sound insulation housing – or ancillary room, see also Sec. 5.4).
- Special settings (larger airflow window, longer delay time etc.) may have to be made in areas with significant temperature fluctuations of more than 20°C at both the sampling pipe and on the detector housing.
- In spaces with high ambient temperatures of > 50°C and/or a humidity of > 80%, cooling sections may have to be used in the sampling pipe.
- Only those materials listed and approved by the manufacturer are to be used to create the system (component of the device approval according to EN 54-20). Materials from other sources may be used only if the manufacturer's written consent has been obtained.
- It is **not** permitted to monitor ex-zones with the ASD 531.
- The environmental influences as listed in Sec. 4.11 must be observed.

Equipment monitoring (additional):

See Sec. 4.5

4.11 Environmental influences



Notices

- On the basis of the conducted tests, the ASD 531 may be used in an environment that is within the scope of the type approvals. The environmental conditions as described in Sec. 13 must also be observed. Non-observance can negatively impact proper functioning of the ASD 531.
- For special applications (e.g. in Arctic or tropical climates, in marine applications, high-level EMC environments, high shock impact, etc.) please contact the manufacturer of the ASD 531 for empirical values and special application guidelines.

4.12 Use compliant with UL 268, UL 268A and ULC-S529

For use compliant with **UL 268**, **UL 268A** and **ULC-S529** the following alarm sensitivity ranges of the used smoke sensor in the ASD 531 must be adhered to.

Special applications (system limits as defined in this document, Sec. 4 and ff.)		
Sensitivity range	0.02 – 10 %/m	0.0061 – 3.1604 %/ft
High velocity range	0 – 20 m/s	0 – 4000 ft/min
Sampling holes	as defined in this manufacturer document	

Open area protection, replaces spot-type smoke detectors for triggering evacuation systems		
Sensitivity range	1.63 – 1.75 %/m	0.5 – 0.53 %/ft
High velocity range	0 – 20 m/s	0 – 4000 ft/min
Sampling holes	4 a 84 m ² , max. 336 m ²	4 a 900 ft ² , max. 3600 ft ²

Duct applications		
Sensitivity range	1.63 – 10 %/m	0.5 – 3.1604 %/ft
Velocity range	1.5 – 20 m/s	300 – 4000 ft/min
Sampling holes, system limits	as defined in this manufacturer document (see also in Sec. 4.6)	

5 Mounting

5.1 Mounting guidelines



Notices

Material and products. When the installation is set up, only the following supplied, approved and listed materials may be used:

- Detector housings, smoke sensors, additional modules;
- Tube materials and fittings for the sampling pipe, accessory materials, pipe clamps (according to T 131 194).

Materials from other sources do not conform to EN 54-20 approval and may only be used if the manufacturer's written consent has been obtained.

Installation materials such as cables, intermediate distributors and fastening materials are usually supplied by the customer.

Tools for handling the detector housing; the tools listed below are required for mounting and installation (sorted in the sequence in which they are used in this document):

- | | |
|--|---------------------------------------|
| • Opening the detector housing | flat-blade screwdriver No. 5 (8 mm) |
| • Removing the pipe plug | flat-blade screwdriver No. 2 (4 mm) |
| • Securing the detector housing | Torx screwdriver T20 |
| • Module holder for additional modules | Torx screwdriver T15 |
| • Terminals | no. 1 flat-blade screwdriver (3.5 mm) |
| • Replacing printed circuit board AMB | Torx screwdriver T10 |
| • Replacing the aspirating fan unit | Torx screwdriver T15 |

5.2 Dimensioned drawing / drilling plan for the detector housing

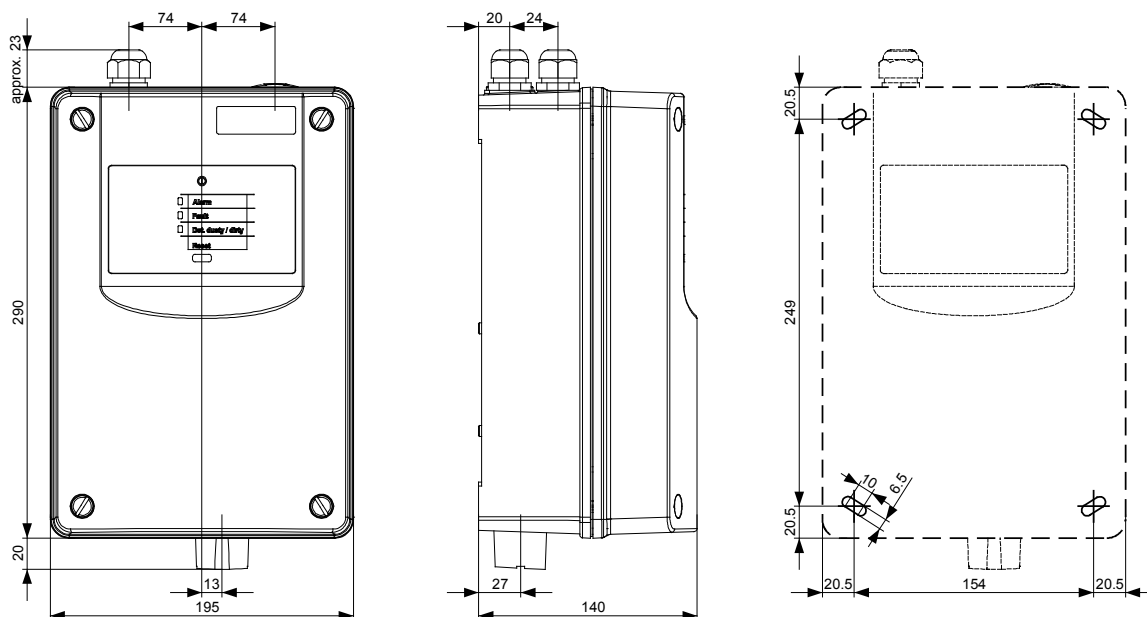

Fig. 15 Detector housing dimensioned drawing and drilling plan

5.3 Material for the sampling pipe



Notices

Tube materials and fittings must be rated at least as Class 1131 of norm **EN 61386-1**. Document **T 131 194** lists materials that meet this standard; it is part of the device approval of the ASD 531 according to EN 54-20.

Other materials do not conform to the EN 54-20 standard and may be used only if the manufacturer's written consent has been obtained and the following conditions are met.

- Compression resistance = min. 125 N (EN 61386-1)
- Shock resistance = min. 0.5 kg, fall height of 100 mm (EN 61386-1)
- Temperature range = min. -15 °C to +60°C (EN 61386-1)
- Tube inner diameter = 19 to 22 mm
- Bending radius, bend = min. 30 mm.

The tube material is available in various plastics and metals. The individual plastic tube parts are usually glued. The flexible tube material for equipment monitoring is pluggable. The metal tubes are connected by means of press fittings.

The rigid plastic tubes can be shaped by heating. The tubes can be painted a different colour, although attention must be paid to the chemical compatibility between paint and tube.

The following materials are available:

Material	Connection
PVC (polyvinyl chloride, contains halogen)	Gluing
ABS (acrylonitrile-butadiene styrene, contains halogen)	Gluing
PA (polyamide, contains no halogen)	Plug-in connection
Copper	Press fitting
Stainless steel	Press fitting



Notice (see also Sec. 9.5.1)

- The two materials that use adhesives (PVC and ABS) must not be combined as different adhesives are used.
- Transitions from PVC or ABS to PA materials (flexible tube parts) are possible using special adhesive-screw junctions.
- As a material, PVC releases corrosive and toxic gases if burned or improperly disposed of. The use of PVC materials should therefore be restricted to wherever it is expressly permitted by the operator of the installation. In applications stipulated the use of halogen-free plastics, ABS or PA materials must be used for laying the sampling pipe. Country-specific guidelines and regulations must be observed.
- The adhesives and cleaning agents used for connecting PVC and ABS materials contain solvents and are combustible. For this reason, prior to working with these materials it is imperative to read and observe the safety instructions and information provided by the adhesive supplier.

A list of the available **materials for the sampling pipe** (pipes, fittings etc.) for the ASD 531 is available in a separate document (**T 131 194**).

5.4 Mounting the detector housing



Notices

- Mounting work on the detector housing is best carried out without the smoke sensors fitted.
- The smoke sensor is always installed in the detector box just when the ASD 531 is commissioned (see Sec. 6.3).
- Depending on the circumstances (e.g. long periods of time between mounting and commissioning or if the environment is extremely dusty (construction work), the housing cover should be kept closed until the device is commissioned.

The detector housing should always be kept in the room to be monitored. If this is not possible, ensure that the detector housing is located in a room that has the same air pressure or – in the case of air-conditioned rooms – the same climate and pressure zone. In applications where the sampling pipe and detector housing are mounted in different climate zones, a return sampling pipe to the monitored area is required. The return line can be adapted after removing the air outlet pipe plug on the ASD 531 housing. See also under Sec. 4.5, 5.4.2 and 5.4.3. The maximum length for the return line must not exceed 20 m.

Special settings (larger airflow window, longer delay time etc.) may have to be made in areas with significant temperature fluctuations of more than 20°C at both the sampling pipe and on the detector housing. This also applies to temperature differences of more than 20°C between sampling pipe and detector housing.

An easily accessible installation location should be chosen so that the detector housing can be worked on without aids such as ladders and scaffolding. The ideal installation height for the detector housing is about 1.6 m above ground level (top edge of the detector housing).

On the entry side of the sampling pipes a minimum distance of 20 cm from building elements should be maintained (see **Fig. 15**) to enable fastening the housing cover (commissioning and maintenance work). A distance of 10 cm is sufficient on the entry side of the supply cables.

When positioning the detector housing, take into account the fact that the noise caused by the fan may in some cases be perceived as a disturbance. If no suitable location is available for the detector housing, it may be necessary to mount it in a sound insulated cabinet (e.g. ASD sound insulation housing). If air recirculation in the same climate zone as the sampling pipe is necessary, it can be implemented by means of a tube piece out of the acoustically insulated cabinet. The tube piece exiting from the sound insulated cabinet (transition) must be properly sealed. When using the ASD sound insulation housing, an M32 cable screw union is used for the transition. For further details about the ASD sound insulation housing contact the manufacturer.

5.4.1 Opening and closing the detector housing



Notices about opening and closing

- To open the detector box, use a **flat-blade screwdriver no. 5** (8 mm). Smaller flat-blade screwdrivers may damage the material of the rotary snap locks.
- To actuate the **rotary snap locks**, **press** them **firmly** with the screwdriver towards the housing base and then **turn** through 90°. The position of the lock slit shows the current status (see Fig. 16):
 - ⇒ approx. 45° angled toward detector housing corner = closed;
 - ⇒ approx. 45° angled toward detector housing edge = open.
 In either position the rotary snap locks **must** snap into place.

Opening / closing

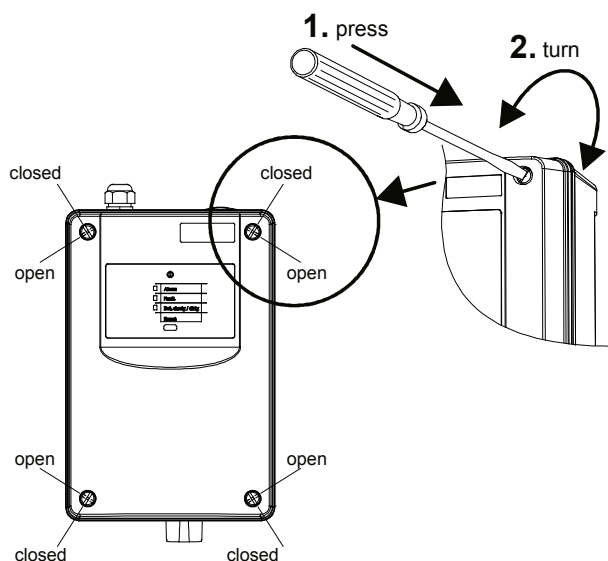

Locking

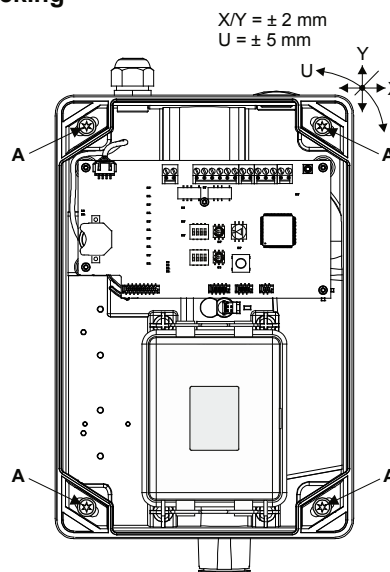

Fig. 16 Open, closing and securing the detector housing

Once the detector housing is open, the four mounting holes in the housing base are accessible.

The detector housing is secured using the four supplied Torx wood screws ($\varnothing 4.5 \times 35$ mm) and the four U-washers ($\varnothing 4.3/12 \times 1$ mm) "A". Use a **Torx screwdriver T20** to insert and tighten the screws.

The positions of the fastening holes are shown in dimensioned drawing **Fig. 15**. When fastening to masonry, use the S6 dowels supplied.



Notice

When mounting several ASD 531 units next to one another, make sure that the mounting holes are **drilled precisely**. The device can be shifted by a maximum of ± 2 mm horizontally and vertically to correct its mounting position. A rotation correction of approx. ± 5 mm is possible.

5.4.2 Mounting positions for the detector housing

In principle the detector housing can be mounted in the X, Y or Z axis. However, because of the labelling for the indicator elements, it is advisable to mount the device in the Y axis (vertical, control unit at the top). The sampling pipe is then inserted into the detector housing from below. This makes it easier to feed the tubes to accessory parts such as filter-box/filter unit and water retaining box, which for physical reasons should always be below the ASD detector housing. If feeding the sampling pipe into the detector housing from above is unavoidable, the detector housing can also be rotated through 180° and then mounted (i.e. with the control unit at the bottom). To ensure that control unit labelling is not upside down, turn the control unit labelling strips accordingly (see Sec. 5.4.4).

To prevent the ingress of dirt, the detector housing ships with the pipe plugs fitted. Likewise all the cable screw unions are sealed. If there is a return sampling pipe back to the monitored area, it can be connected directly to the detector housing in place of the air outlet pipe plug.

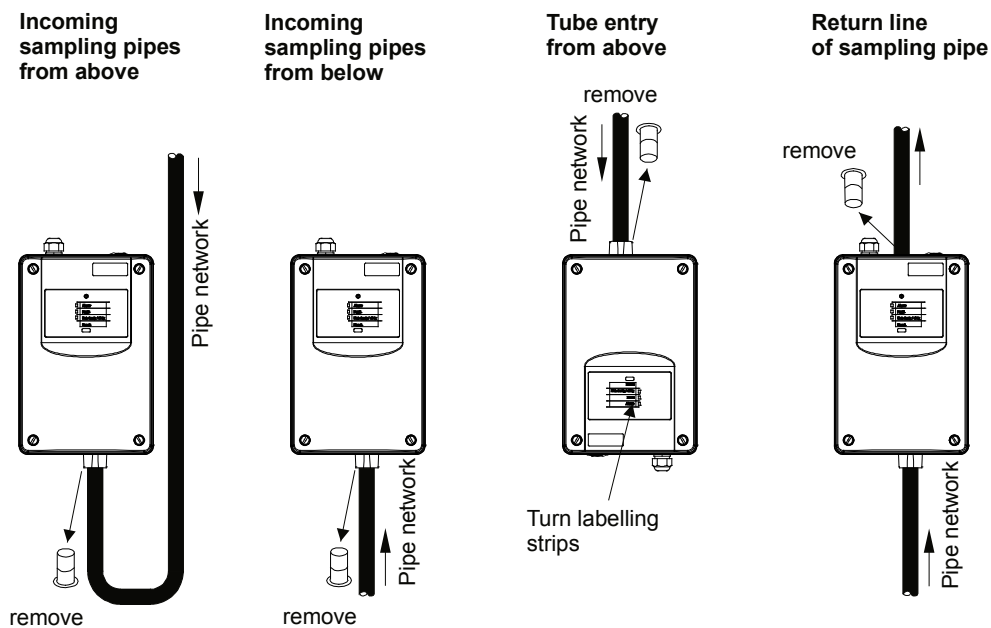

Fig. 17 Mounting position and pipe entries on the detector housing



Notices about pipe entries

- The entry opening in the detector housing is designed so that the sampling pipe simply has to be plugged into place (conical opening). The sampling pipe should only be glued into place in exceptional circumstances and only after consulting with the manufacturer.
- The air outlet pipe plug (with openings) is to be fitted to the air outlet opening only.
- The pipe plugs must not be glued in the ASD housing (plug-in connector).

Mounting

5.4.3 Removing the air outlet pipe plug

Insert the blade of a **flat-blade screwdriver no. 2** (4 mm) into one of the side recesses of the air outlet pipe plug. To release the pipe plug, prise gently toward the ASD housing.

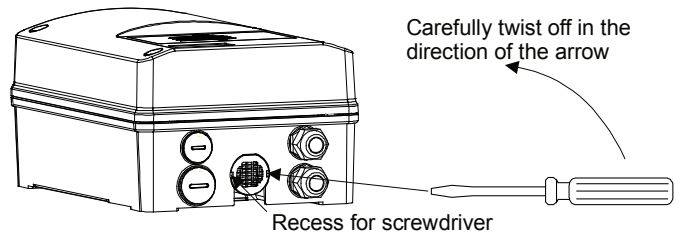

Fig. 18 Removing the air outlet pipe plug

5.4.4 Turning the labelling strip

Open the detector housing to turn the labelling strips. Use the tab to pull the labelling strip out of the cover, turn it over, and then re-insert it into its compartment.

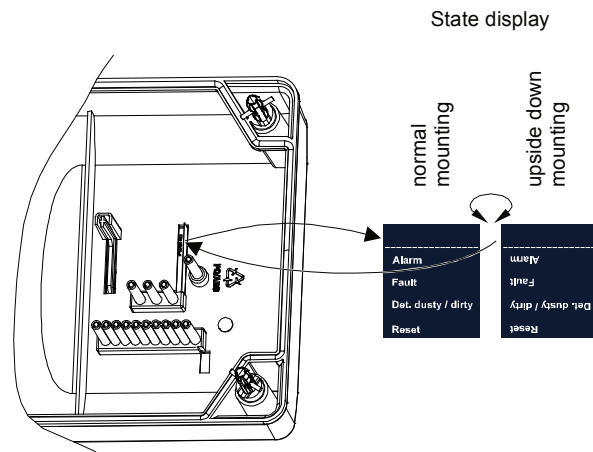

Fig. 19 Turning the labelling strips

5.5 Mounting the sampling pipe

5.5.1 General

The mounting and installation are to be carried out by analogy as specified in Section “Planning” in this document. Any deviation from the layout of the sampling pipe and sampling holes (also outside the limits calculated using “ASD PipeFlow”) is subject to the consent of the manufacturer.

The sampling pipe can be made of hard PVC or halogen-free ABS material, depending on requirements. In special applications – e.g. in extremely corrosive environments – other tube materials can also be used, subject to the specifications set out in Sec. 5.3.



Notice – installation and modification of the sampling pipe

System performance depends on the sampling pipe. Any extensions or modifications to the installation may cause functional faults. The effects of such changes must be checked. It is very important to adhere to the specifications in Sec. 4 (Planning). The “ASD PipeFlow” calculation software is available from the manufacturer.

5.5.2 Mounting with PVC tubes and fittings

As a rule, if the system operator does not specify a halogen-free installation, the sampling pipe can be made using hard PVC tubing. When PVC tube material is installed, the individual tube parts are glued together using a special PVC adhesive (e.g. Tangit for PVC). The adhesive manufacturer’s instructions must be followed. Before gluing, use household paper to remove any dust and grease deposits from the surfaces to be glued (do not use textile cloths). If the tube parts are very dirty, a cleaning agent as specified by the adhesive manufacturer may have to be used.



Notices

- The adhesives and cleaning agents used for connecting PVC materials contain solvents and are combustible. For this reason, prior to working with these materials it is imperative to read and observe the safety instructions and information provided by the adhesive supplier.
- The two glueable materials – ABS and PVC – must not be combined, since different adhesives are used.

5.5.3 Mounting with ABS tubes and fittings

If required, halogen-free ABS material can be used for the sampling pipe. When ABS tube material is installed, the individual tube parts are glued together with a special ABS adhesive (e.g. Tangit for ABS). The adhesive manufacturer’s instructions must be followed. Before gluing, use household paper to remove any dust and grease deposits from the surfaces to be glued (do not use textile cloths). If the tube parts are very dirty, a cleaning agent as specified by the adhesive manufacturer may have to be used.



Notices

- The adhesives and cleaning agents used for connecting ABS materials contain solvents and are combustible. For this reason, prior to working with these materials it is imperative to read and observe the safety instructions and information provided by the adhesive supplier.
- The two glueable materials – ABS and PVC – must not be combined, since different adhesives are used.

Mounting

5.5.4 Mounting with metal pipes and fittings

Metal tubes (copper, stainless steel) are connected using press fittings according to the manufacturer's instructions. For this purpose, commercially available radial pressing tongs (e.g. REMS radial pressing tongs) with the appropriate V pressing contours can be used.

5.5.5 Linear expansion

Plastics have sizeable linear temperature expansion coefficient, which is why special attention should be given to the linear expansion (extension and contraction) of the sampling tube. An increase in temperature causes the tube to expand; a decrease in temperature causes it to contract. The importance of taking linear expansion into account increases as the temperature at the time of installation deviates from the usual operating temperature.

Linear expansion can be calculated as follows:

Calculation: $\Delta L = L \times \Delta T \times \alpha$

ΔL = Linear expansion in mm
 L = Length in metres of the sampling pipe between two fixed points
 ΔT = Temperature change in °C
 α = Linear expansion coefficient in mm/m°C
for **PVC** = 0.08
for **ABS** = 0.10

Example: sampling pipe length 20 m, anticipated temperature change 10°C, material PVC:

Calculation: $\Delta L = 20 \times 10 \times 0.08 = 16 \text{ mm}$



Notice

For straight layout the linear expansion can be up to **80 mm** over the total sampling pipe length (40 m) within the permitted temperature fluctuation range (20°C). It is therefore essential to ensure that the sampling pipe is able to "move" (slide) inside the clips/pipe clamps. A distance of 100 mm (0.1 m) must therefore be maintained between the last clip or fastening clamp and the end cap.

5.5.6 Mounting the sampling pipe

Notice

When mounting the sampling pipe, make sure the points listed below are noted and observed (see Sec. 5.5.5).

- Clips and pipe clamps at 1 m intervals are used to fasten the sampling pipe.
- The tubes must be cut to size using a pipe cutter. In doing so, ensure that the cut is at a right-angle to the tube axis. Remove any projecting burrs, **Fig. 20**.
- The ends of the individual tube pieces are to be bevelled slightly using a suitable tool, e.g. slightly bevel with a pipe scraper, **Fig. 20**.
- The individual tube sections are connected using fittings. Depending on the tube material used, use either the adhesive process described in Sec. 5.5.2 and 5.5.3 or the pressing process described in Sec. 5.5.4. The tubes are pushed into the fittings as far as the stop, **Fig. 21**.
- The connection points must be sealed tight to prevent the intake of any leakage air.
- If the sampling pipe or parts thereof is laid out vertically (e.g. in a riser), make sure the tubes cannot slide down (secure clips directly below the fittings as shown in **Fig. 22**).
- The sampling pipe must be fastened so that the tube is able to “operate” within the clips (linear expansion, see Sec. 5.5.5).
- A distance of at least 0.2 m must be maintained from the T-piece to the clips, starting from the branching points of the sampling pipe, **Fig. 23**.
- For changes of direction in the space surveillance, it is advisable to use 90° bends rather than 90° angles, **Fig. 23** (see also Sec. 4.4.2).
- For flush mounting or mounting in false ceilings, ensure that the tubes are not able to start oscillating by themselves.
- The exact definitive layout of the tubes – particularly in the case of flush mounting – must be documented precisely on the installation plans complete with dimensions.

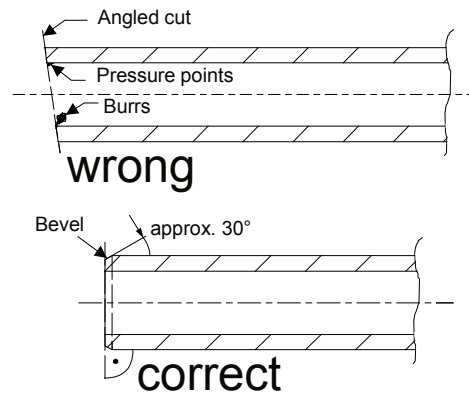

Fig. 20 Cutting the tubes

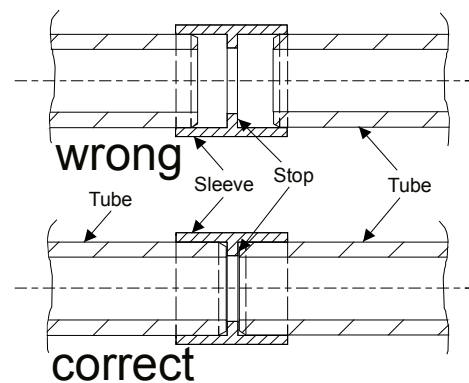

Fig. 21 Assembling the tubes

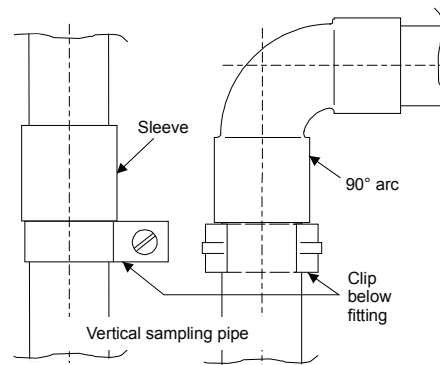

Fig. 22 Vertical sampling pipe

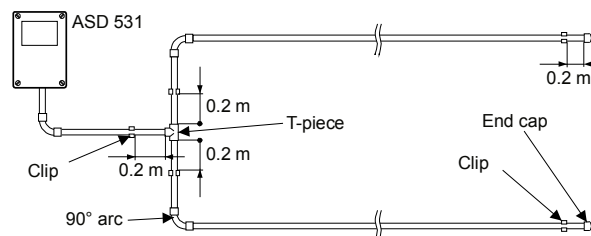

Fig. 23 90° bend, branching point

5.5.7 Mounting for equipment monitoring

When mounting for equipment monitoring (EDP installations, electrical cabinets etc.), plastic tube materials are to be used in principle. The same guidelines as described in Sec. 5.5.6 apply.

Equipment monitoring involves monitoring all the air outlet openings of the monitored devices.

Whenever possible, the sampling pipe and detector housing are always secured directly to the object to be monitored.

5.5.7.1 Screw-free fastening of the sampling pipe

Use the click-on pipe clamps to secure the sampling pipe parts (sampling fixtures) without screws. This allows the sampling fixture or sampling pipe to be removed quickly during maintenance work on the monitored objects.

The click-on pipe clamps are screwed onto the support rails by means of threaded plates.

The support rails are best fastened at right angles to the tube axis to ensure a precise positioning of the sampling pipe (sampling fixture).

Double-sided adhesive tape is used to secure the support rails in the desired position on the object, **Fig. 24**.

Before using the double-sided adhesive tape, make sure the adhesion surfaces are cleaned with a **non-aggressive** cleaning agent (e.g. soap suds or similar).

Cable ties can also be used for securing purposes instead of the double-sided adhesive tape.

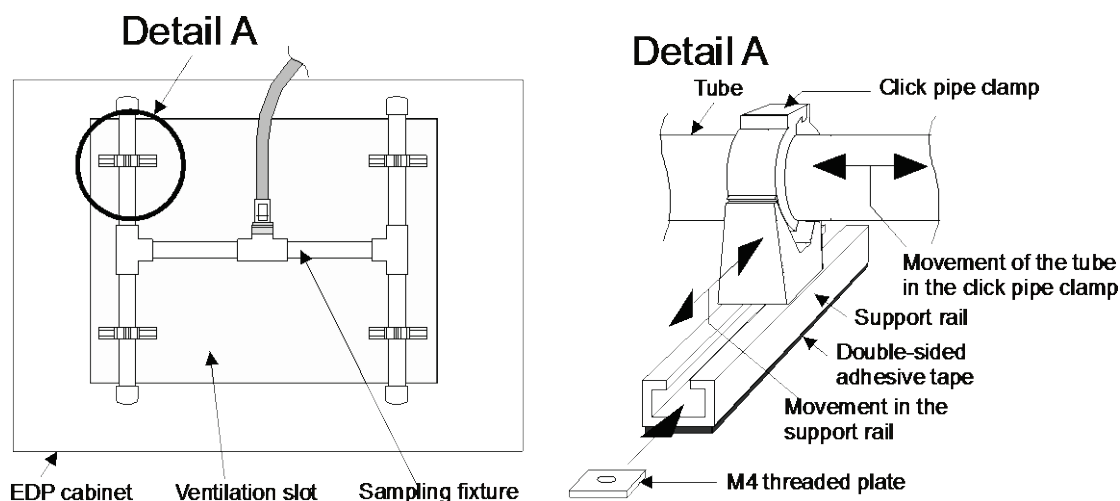

Fig. 24 Screw-free fastening of a sampling fixture

5.5.7.2 Transition to a flexible tube

The transition from rigid to flexible tube can be made in principle using any type of fitting. The parts shown in **Fig. 25** are used for that purpose.

For a rigid sampling pipe made of **PVC** a **PVC threaded ring** with M20 internal thread is glued into the exit side of the fitting. The M20 quick-release coupling is screwed into the adapter for the flexible tube.

If the rigid sampling pipe is made of **halogen-free ABS**, the procedure is identical to that for PVC. Instead of the PVC threaded ring, however, a suitable **threaded ring made of ABS** is used.

The flexible tube is simply snapped into the quick-release coupling and snapped out of it again just as easily for maintenance work.

Notices

- Make sure the interfaces of the flexible tube are implemented “cleanly” so that the sealing ring in the quick-release coupling is not damaged.
- When clicking the flexible tube into place, make sure the tube and the quick-release coupling are pressed firmly against each other to prevent the intake of any leakage air.

For transitions from flexible tubes to sampling fixtures, proceed in the reverse order described above.

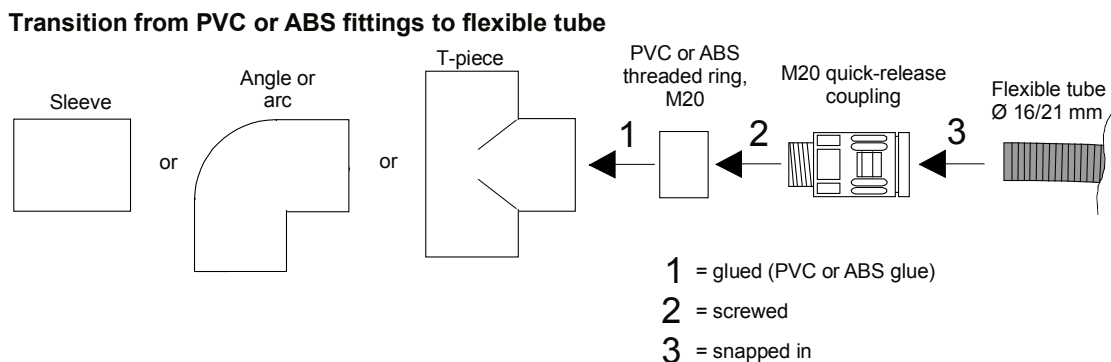

Fig. 25 Transition from fittings to flexible tube

5.5.8 Creating the sampling holes

The hole diameters for the sampling holes have to be determined and created by the customer as described in Sec. 4.4.4.3 and according to the specifications of the “ASD PipeFlow” calculation software.

The sampling holes must be drilled cleanly so that no burrs or pressure points result. Use “new” drills with correctly ground surfaces (Fig. 26).

Whistling noises are a sign that the holes have not been neatly drilled. If so, the holes should be re-drilled and/or deburred.

For space surveillance, the sequence of hole diameters set out in Sec. 4.4.4.3 and the specifications of the “ASD PipeFlow” calculation software must be observed strictly.

If required, the sampling holes can be made using the special “sampling hole clips” (see 5.5.9).

For equipment monitoring, the sampling holes are drilled in the sampling fixture. The sampling holes are drilled into the sampling fixture in the direction of the air outlet from the object to be monitored. If required, these sampling holes can be fitted with sampling funnels (Sec. 5.5.10).

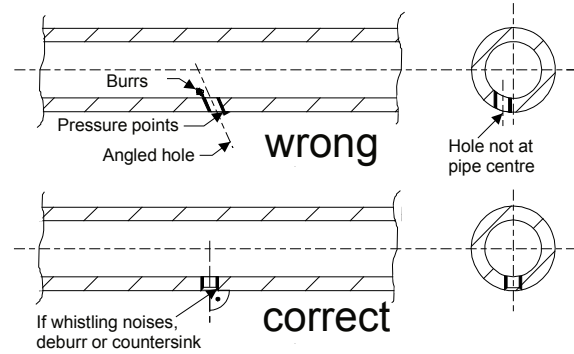

Fig. 26 Creating the sampling holes

5.5.9 Mounting the sampling hole clips and maintenance clips

Possible only with plastic tubes (PVC/ABS)!

At each required position in the sampling pipe drill a hole 8.5 mm in diameter (uniform Ø). The holes are made at right angles, in the centre of the pipe axis (as shown in Fig. 26).

The sampling hole clips are available in various sizes (Ø 2.0 / 2.5 / 3.0 / 3.5 / 4.0 / 4.5 / 5.0 / 5.5 / 6.0 / 6.5 / 7.0 mm). To determine the required sampling hole clips, refer to Sec. 4.4.4.3 and the specifications of the “ASD PipeFlow” calculation software.

The sampling hole clips and the maintenance clips are clipped onto the sampling tube so they snap into the 8.5 mm borehole, Fig. 27.

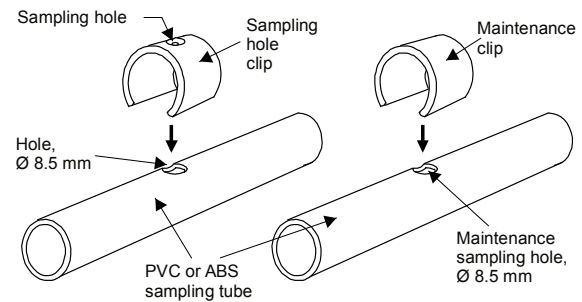

Fig. 27 Mounting clips

5.5.10 Mounting the sampling funnel

Possible only with plastic tubes (PVC/ABS)!

On objects with a high air-flow rate (strong ventilation), the sampling holes can be fitted with funnels for optimal smoke detection.

If forced ventilation is used in rooms and/or on equipment, the use of sampling funnels is imperative.

The sampling funnels are fastened to the tube and adjusted on the previously drilled sampling holes, Fig. 28.

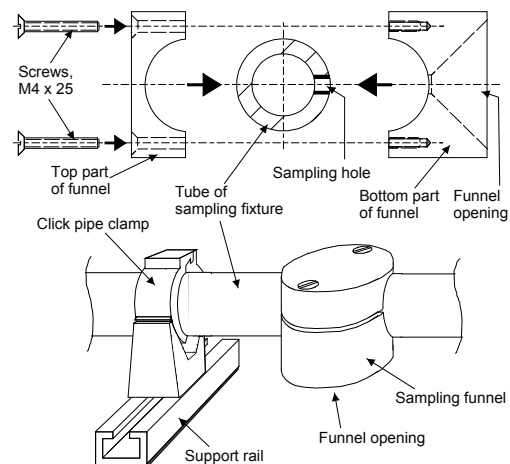

Fig. 28 Using sampling funnels

5.5.11 Mounting sampling stubs for a ceiling bushing

Possible only with plastic tubes (PVC/ABS)!

The parts required for a sampling stub for a ceiling bushing duct are shown in **Fig. 29**.

A T-piece is built into the sampling pipe at the required point.

The assembly sequence is carried out as indicated by the numbering **1 to 8**.

The sampling hole size (8) is selected based on the specification in Sec. 4.4.4.3 and/or the specifications of the “ASD Pipe-Flow” calculation software.

Notices

- Make sure the interfaces of the flexible tube are implemented “cleanly” so that the sealing ring in the quick-release coupling is not damaged.
- When clicking the flexible tube into place, make sure the tube and the quick-release coupling are pressed firmly against each other to prevent the intake of any leakage air.
- The maximum length of the flexible tube must not exceed **1.5 m**.

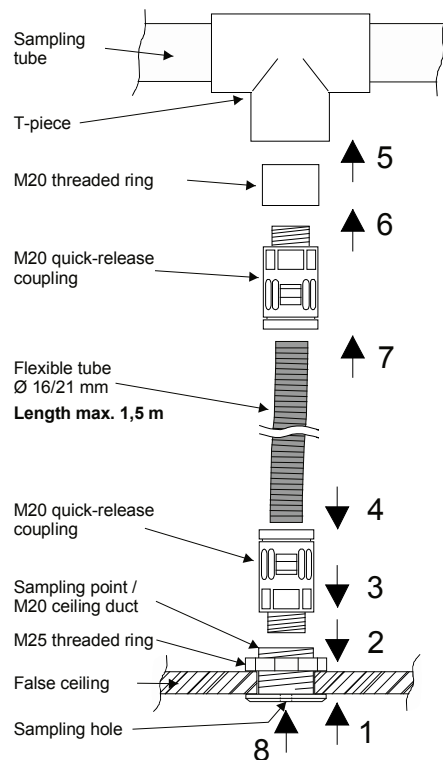

Fig. 29 Mounting the ceiling bushing

5.5.12 Mounting the filter-box, filter unit, dirt trap box, dust retaining box, water retaining box

Applications with extremely high levels of dust and/or dirt, extreme temperature ranges and/or atmospheric humidity outside the specified limit values require the use of accessory parts as instructed by the manufacturer, e.g.:

- Filter-box/filter unit;
- Dirt trap box;
- Dust retaining box;
- Water retaining box;
- Manual ball valve for sporadic cleaning of the sampling pipe using compressed air;
- Automatic blow-out device



Notices

The following rules must be adhered to when using accessory parts:

- The use of a filter-box and/or filter unit by itself is possible.
- The water retaining box, dust retaining box and dirt trap box should always be used in conjunction with a filter-box and/or filter unit.
- An automatic blow-out device should be used in combination with a dust retaining box or a dirt trap box and a filter-box and/or filter unit.
- Filter-boxes/filter units, dirt trap boxes, dust retaining boxes and water retaining boxes must always be mounted below the detector housing. The water retaining box and dust retaining box must be located at the lowest point (water drain). The specified minimum dimensions (0.5 m) must be adhered to.
- The mounting positions for the water retaining box, dirt trap box and dust retaining box must be observed as indicated in Fig. 30.

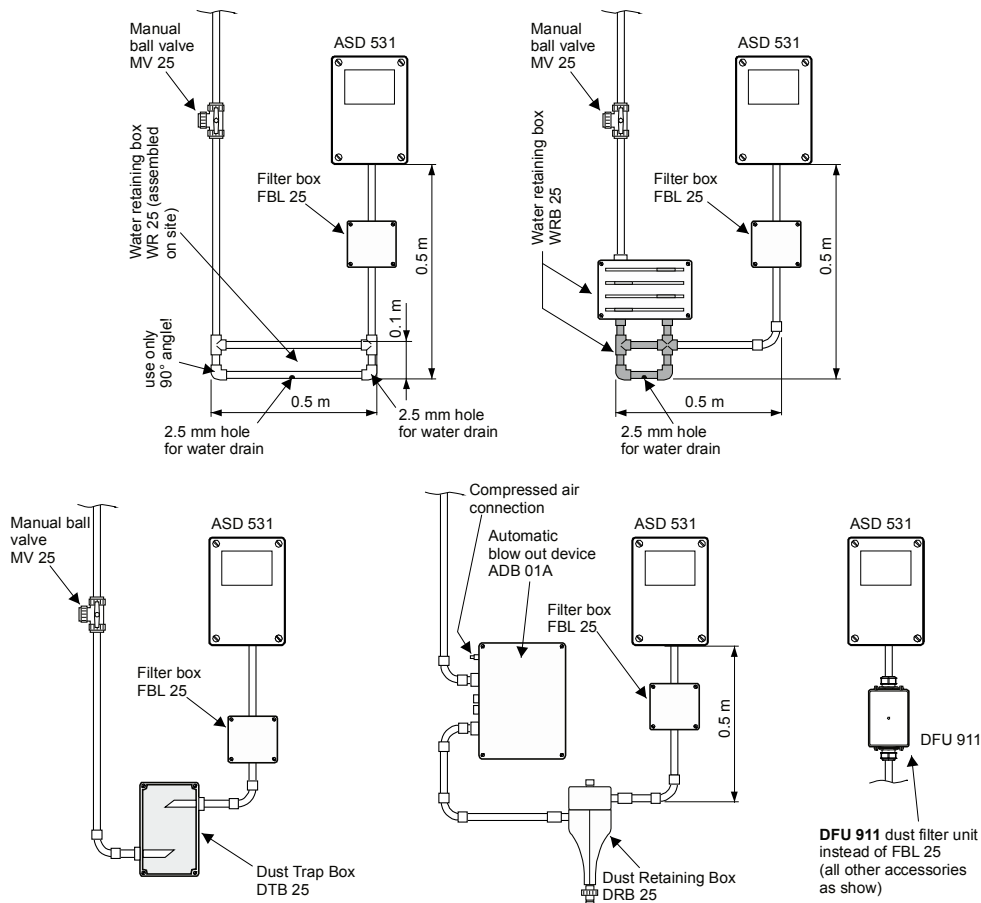

Fig. 30 Mounting accessory parts

6 Installation

6.1 Regulations



Notices

- The electrical installation is to be carried out in accordance with the applicable country-specific regulations, standards and guidelines. Likewise, the local provisions must also be observed.
- Besides country-specific regulations and guidelines, the specifications concerning the requirements for installation cables and conductor cross-sections as described in Sec. 4.9 must be observed and implemented.

6.2 Cable entry



Notice

Make sure the power is disconnected for all connection and wiring work on the ASD 531.

There are two M20 cable screw unions in the detector housing for feeding in the electrical installation. If needed, an additional two cable screw unions (1 x M20, 1 x M25) can be fitted in two reserve holes (blind plugs).

The cable screw unions are suitable for cables with external diameters ranging between 5 and 12 mm (M20) or 9 and 18 mm (M25).



Notices

- The device ships with the cable screw unions sealed with a dust-protection insert; remove the inserts before feeding in the cables. The dust-protection inserts merely prevent the ingress of any dust and/or dirt during the mounting of the device and do not provide any mechanical protection. Any cable screw unions that are not in use must be replaced with blind plugs (mounting set) to maintain the IP 54 protection class.
- **Use in compliance with UL 268:** When using the ASD 531 in compliance with UL 268, special 1/2" and 3/4" cable screw unions are to be used (customer-side). To be able to use them in the ASD housing, the existing M20 and M25 screw-junction pieces must be removed and replaced by 1/2" M20 adapters and 3/4" M25 adapters. The adapters are available from the manufacturer in the **AD US M-Inch** range of accessories.

6.3 Deploying smoke sensors

The ASD 531 ships with the smoke sensor already fitted. The smoke sensor has to be removed from the detector housing for the installation of the ASD (release the two lock clamps); however it should be left inside its protective packaging until the definitive commissioning. The definitive installation is carried out as described below.



Notices when deploying the smoke sensor

- Always leave the smoke sensor inside its protective packaging until just before it is to be installed in the detector housing.
- Depending on the situation (e.g. if there is a long time between mounting and commissioning or if the environment is very dusty due, for example, to construction), the smoke sensor should be installed just before commissioning the ASD 531.
- Before installing the smoke sensor check that the insect protection screens are properly fitted to the smoke sensor chamber at the air inlet and outlet.
- The smoke sensor chamber must be absolutely free of any dirt and/or dust. Remove any residue resulting from mounting the detector housing.

Check the installation position when installing the smoke sensor. The connector plug of the smoke sensor must be face away from the slots of the additional modules. The anti-twist rib on the smoke sensor case prevents an incorrect installation position.

The smoke sensor is secured inside the ASD housing using the two lock clamps. Connect the ribbon cable supplied with the smoke sensor to the smoke sensor (large ribbon cable connector) and to the AMB 31 main board (small ribbon cable connector).

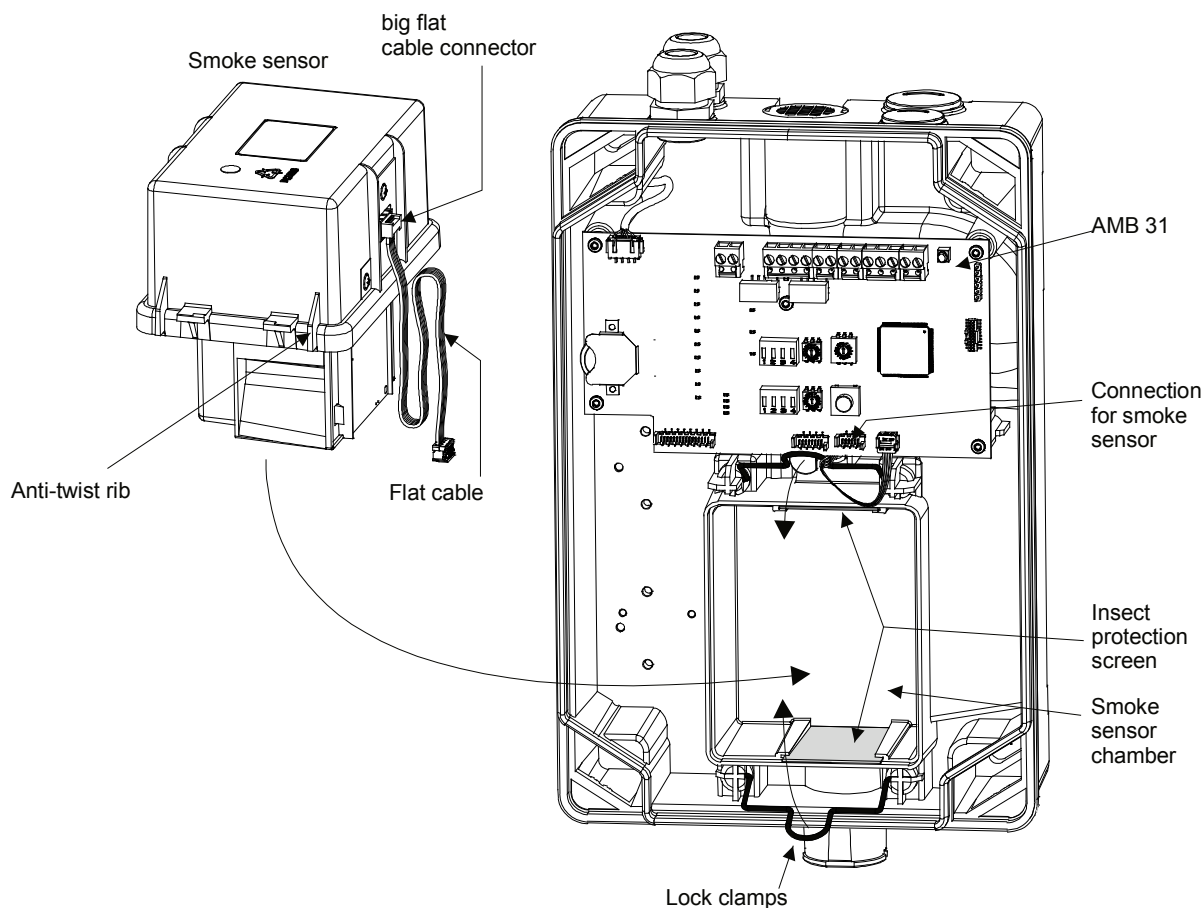

Fig. 31 Deploying the smoke sensors

6.4 Installing additional modules XLM 35, RIM 36

There are two expansion slots for fitting the detector housing with optional additional modules. Given the modular assignment of ribbon cable connectors on the AMB 31 Main Board (see also Sec. 3.2, Fig. 5), it is recommended to observe the arrangement shown in Fig. 32.

The mounting set of each module comprises a module holder, mounting screw and the connecting cable (ribbon cable) for connecting to the AMB 31. Use a **Torx screwdriver T15** to tighten the mounting screw. The module can be removed from the module holder for mounting in the detector housing and for the subsequent electrical installation.

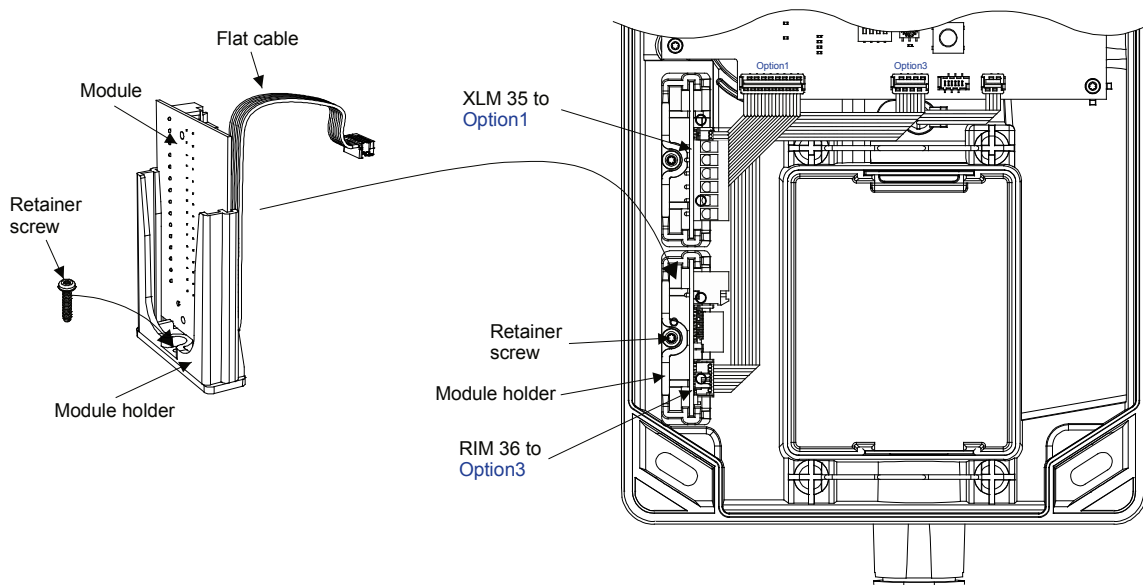

Fig. 32 Installing additional modules



Notice

The additional modules are automatically detected when the device is switched on, from which point on they are monitored and functional. To read out the SD memory card or when subsequently removing an additional module (e.g. because it is not being used), the additional modules must first be logged off via operation on the AMB 31 Main Board (**3** switch position, see Sec. 7.3.8).

The UMS 35 universal module holder is available for installing modules other than XLM or RIM. It is secured in the detector housing instead of the module holders described above and requires both expansion slots. The UMS 35 consists of an angled sheet metal plate with various fastening options for additional modules.



Notice, XLM 35 installation

With the installation of the use of an XLM 35, the ASD 531 meets the requirements in compliance with **EN 54-17** (short-circuit isolation). To ensure that the required identification is recognisable in compliance with EN 54-17, the supplied **identification sign must** be easily visible **outside** on the ASD housing and attached in the immediate vicinity of the ASD rating plate (same side) when the XLM 35 is installed.

6.5 Electrical connection

The electrical connection is implemented by means of plug-in screw terminals. Use a **no. 1 flat-blade screwdriver** (3.5 mm) to tighten the screw terminals. Individual terminal blocks are fitted for the supply voltage, relay contacts, inputs, outputs, etc.



Notices

- Inside the detector housing the lines should be fed to the terminals using the shortest possible route. Reserve loops via the main board are to be avoided (EMC).
- **Caution:** For system monitoring – for terminals “Alarm” and “Fault”, **do not use looped wire** under terminals. Break wire run to provide monitoring of connections.

6.5.1 Terminal assignment Main Board AMB 31

AMB terminal	Signal	Wiring
1	+14 to +30 VDC (UL/FM = 16.4 to 27)	Main supply line from FACP or external according to Fig. 33
2	0 V	
3	+14 to +30 VDC (UL/FM = 16.4 to 27)	Redundant supply line from FACP or external according to Fig. 33
4	0 V	
5	+ power supply	Connection of feedback signals according to Fig. 40
6	Output fault, OC (all fault events)	
7	Output Alarm, OC	
8	Rel. 1 (“NO”) ①	Fault
9	Rel. 1 (“NC”)	
10	Rel. 1 “COM” ①	
11	Rel. 2 “NO”	Alarm
12	Rel. 2 “NC”	
13	Rel. 2 “COM”	
14	External reset input + (opto-isolator input)	Connection according to Fig. 34 and Fig. 36
15	External reset input – (opto-isolator input)	



Notice

- ① The “Fault” relay has picked up in the release state → contact Te. 10/8 closed, 10/9 open (ASD 531 under voltage; no fault event present).

6.5.2 Terminal assignment for eXtended Line Module XLM 35

XLM terminal	Signal	Wiring
L1	Data A	Addressable loop according to Fig. 36 or Fig. 39 (see also Sec. 8.5.5)
C1	GND A	
G1	Screen	
L2	Data B	Addressable loop according to Fig. 36 or Fig. 39 (see also Sec. 8.5.5)
C2	GND B	
G2	Screen	

6.5.3 Terminal assignment for RIM 36 Relay Interface Module

RIM terminal	Signal default	Signal alternative ①	Wiring
1	"NO"	Pre-signal 1	Alarm
2 Rel. 1	"NC"		
3	"COM"		
4	"NO"	Pre-signal 2	Alarm
5 Rel. 2	"NC"		
6	"COM"		
7	"NO"	Pre-signal 3	Alarm or fault ②
8 Rel. 3	"NC"		
9	"COM"		
10	"NO"	Smoke sensor: dust / dirt / fault	Alarm or fault ②
11 Rel. 4	"NC"		
12	"COM"		
13	"NO"	Sampling pipe: pipe blockage / pipe breakage / fan fault	Fault ②
14 Rel. 5	"NC"		
15	"COM"		

Local info or connection to FACP input



Notices

- ① If you toggle "Relay" DIP switch 4 (ON position), the alternative relay assignment is in effect instead of the default relay assignment.
- ② The following faults are included here:
 - ⇒ Smoke sensor; dust, dirt, fault
 - ⇒ Sampling pipe; pipe blockage, pipe breakage
 - ⇒ General; fan, initial reset, undervoltage, clock

6.6 Connection variants



Notice

The connection variants are determined by the possible line and FACP technologies used. For more information on connecting alarm transmitters, line monitoring elements, etc., please contact the manufacturer and/or supplier of the fire alarm system.

In all cases the ASD 531 must have an emergency power supply (country-specific, e.g. compliant with EN 54-4).

6.6.1 Power supply

The ASD 531 must always have an emergency power supply. Depending on the output current available at the fire alarm control panel (FACP) and the number of ASD 531 units to be connected, the power supply can be provided by the FACP; alternatively, an additional power supply must be provided locally.

The supply is via terminals 1 and 2. In applications which stipulate a redundant power supply line (country-specific), it is routed to terminals 3 and 4 (Fig. 33).



Notices

- The supply inputs are not connected internally in the ASD and therefore cannot be used for direct forwarding to neighbouring systems.
- The terminals of the ASD 531 are designed for maximum 2.5 mm². For forwarding the supply line to a neighbouring ASD it may therefore be necessary to install additional distributor or support terminals.

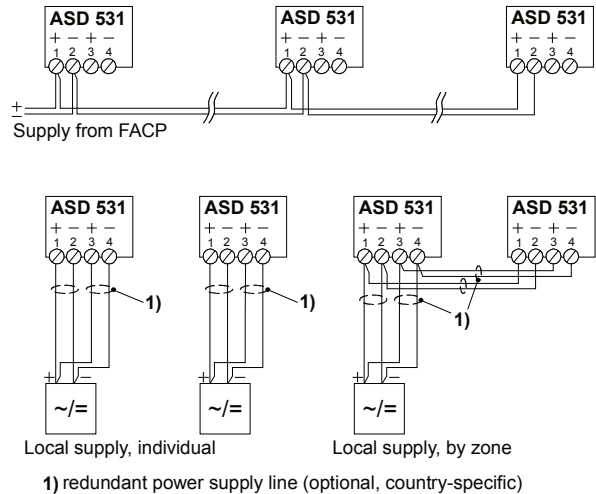

Fig. 33 Types of power supply



Notice

To determine the required power supply and cable cross-section, the calculations set out in Sec. 4.9.2 must be carried out in all cases. For applications with redundant power supply, the calculations must be performed for both power supply lines individually.

6.6.2 Reset input

The reset input is potential-free (opto-isolator) and can be actuated on both the “plus” side and the “minus” side, Fig. 34. The input operates in the 5 to 30 VDC range and a pulse bandwidth of 0.5 to 10 s. Thanks to the continuous current consumption of approx. 3 mA across the entire operating range, actuation can be carried out directly via an OC output.

If a continuous signal is imposed for longer than 20 s, the ASD 531 is switched inactive, the fault relay becomes active (triggers), and the fan is switched off. Once the continuous signal is switched off, the ASD is re-armed. Switching inactive via the “Reset external” input works only if the ASD 531 is not equipped with an XLM 35.

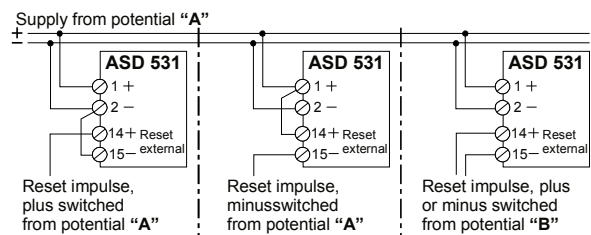

Fig. 34 Reset input

6.6.3 Control

The ASD 531 units connected to an FACP are controlled according to the detection zone mapping using the FACP states “Zone ON/OFF” and “Reset”. Two possibilities are available:

- Control via supply voltage (auxiliary relays in the ASD power supply line);
- Control via the “Reset external” input.

6.6.3.1 Control via voltage supply by means of auxiliary relay

Depending on the location of the ASD power supply, the auxiliary relay may be placed in the FACP or directly in the ASD 531.

The auxiliary relay can be actuated in the following ways (see Fig. 35):

- line plus or minus
- SW output of the FACP
- SW output or function of a control module

The function types described above are determined by the FACP technology used; it is therefore essential to contact the manufacturer and/or the supplier of the FACP for details before implementing.

!

Notices

- The EMC protective elements at the input of the ASD electronics cause a brief current peak (5 A / 1 ms) when the supply voltage is applied. When using auxiliary relays with a maximum contact rating of 1 A, this may lead to the relay contact sticking. For this reason auxiliary relays with a contact load of over **1 A** should **generally** be used, e.g. PMR 81 semi-conductor relay (see Fig. 35c).
- The ASD supply path routed via the auxiliary relay contact must be short-circuit-proof or routed via a fuse component (circuit-breaker card).
- When using a PMR 81 semi-conductor relay, it may be necessary to invert the actuation signal (PMR only has a normally open (NO) contact function).
- To guarantee comprehensive emergency running properties, the connection must in all cases be implemented in such a way that if there is an FACP computer failure the ASD will continue to function (reset input not actuated).

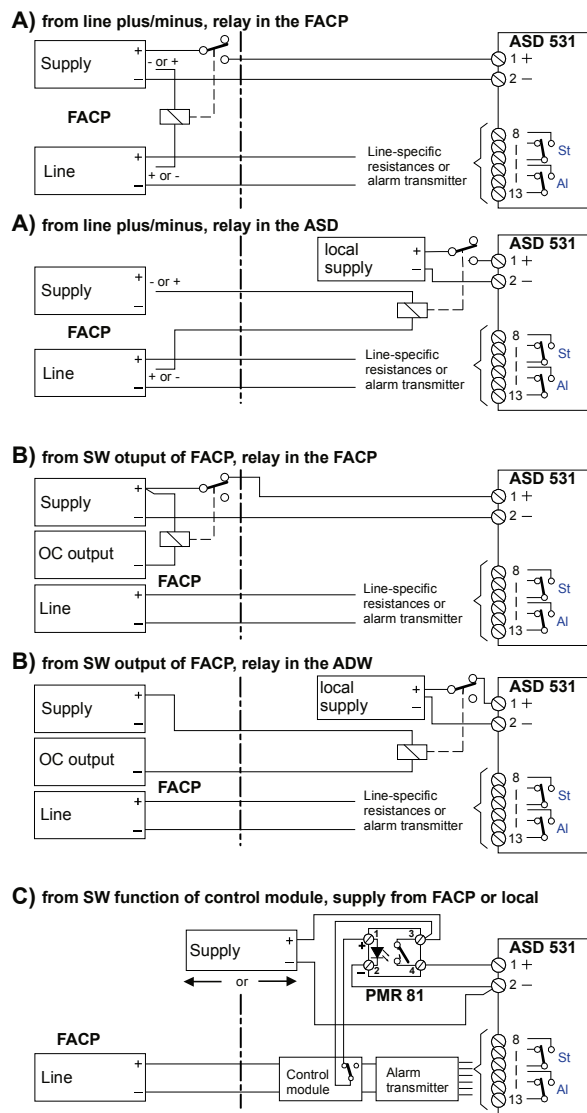

Fig. 35 Control via supply with relay

Installation

6.6.3.2 Control via “Reset external” input

The following options are available for control via the reset input (see Fig. 36):

- A. Control via auxiliary relay from line plus
- B. Control via auxiliary relay or semi-conductor relay (PMR 81) from control output (open collector)
- C. Control without auxiliary relay, directly from control output (relay contact or open collector)
- D. Control via addressable loop when using the XLM 35. The control is then not by means of the reset input but rather directly with the corresponding command entry via the XLM 35 on the ASD 531.

The function types described above are determined by the FACP technology used; it is therefore essential to contact the manufacturer and/or the supplier of the FACP for details before implementing.



Notices

- When using a PMR 81 semi-conductor relay, it may be necessary to invert the actuation signal (PMR only has a normally open (NO) contact function).
- To guarantee comprehensive emergency running properties, the connection must **in all cases** be implemented in such a way that if there is an FACP computer failure the ASD will continue to function (reset input not actuated).
- **Caution:** When control is via the “Reset external” input, the ASD 531 is supplied with voltage even if the zone (FACP) is switched off. For this reason the power supply line to the ASD must be disconnected to carry out any repair work (e.g. unplug terminals 1 and 2 on the ASD; also 3 and 4 in the case of a redundant supply).

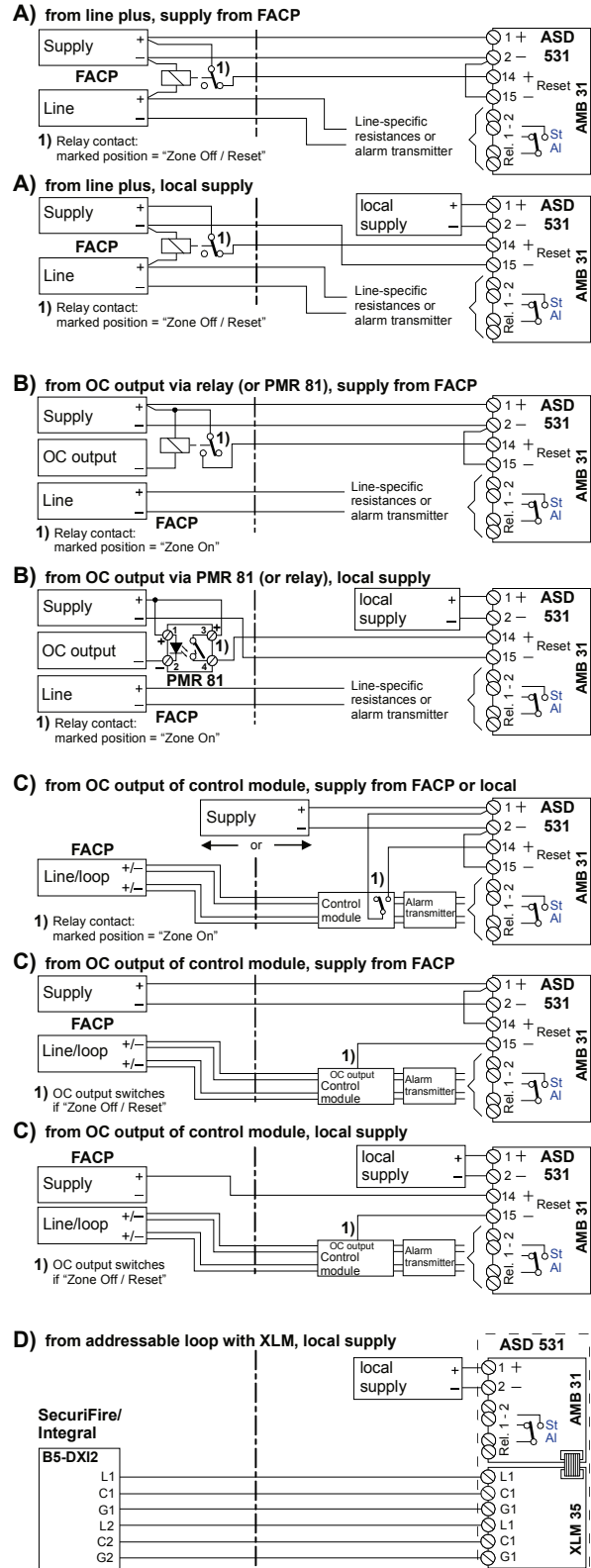

Fig. 36 Control via the “Reset external” input

6.6.4 Connection to the FACP line

Each of the following examples illustrates the control via reset input according to Sec. 6.6.3.2. If connection with the control via the voltage supply is required, the control circuit in the figures below can be implemented as described in Sec. 6.6.3.1.

6.6.4.1 Connection to zone detection via AI / St relays

For connection to zone detection lines, the control relay is usually actuated from the line plus. The precondition is that the line plus also switches for "Zone ON/OFF" and "Reset".

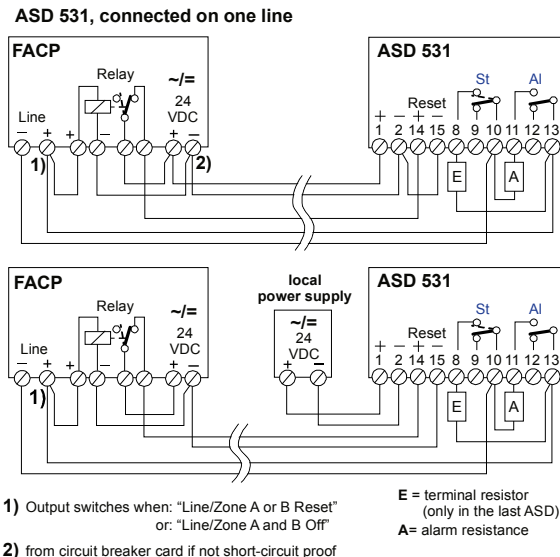

Fig. 37 Connection to zone detection

6.6.4.2 Connection to selective identification or addressable loop via AI / St relays

With line technologies such as selective identification lines and addressable loops, the control relay is actuated from a software-controlled output (output card or control module). The output is programmed via the FACP software using the "Zone Off" and "Reset" functions.

A normal relay or PMR 81 semi-conductor relay can be used as the control relay.

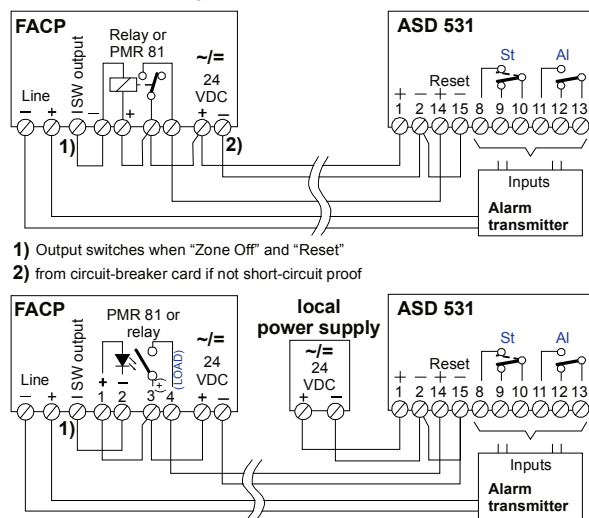

Fig. 38 Connection on selective identification or addressable loop

Installation

6.6.4.3 Connection to SecuriFire / Integral addressable loop from XLM 35

For the connection to SecuriFire/Integral addressable loop from the XLM 35 no additional control relay is needed. Likewise the **Al** and **St** relays of the ASD 531 are not required. The state query and the control of the ASD 531 take place directly between the XLM 35 and the addressable loop.

Maximum connectible XLM 35 units:

(see also notice below)

for each SecuriFire / Integral addressable loop 62 units ①

① country-specific regulations and guidelines must be observed

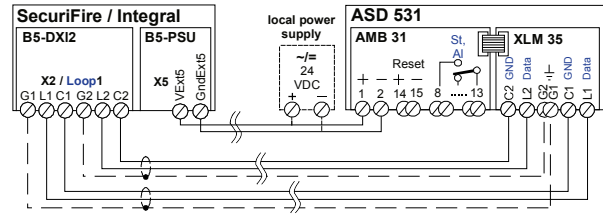

Fig. 39 Connection from XLM 35



Notices

- The installation of the SecuriFire / Integral addressable loop must be shielded.
- The connection and line routing between **XLM 35** and the SecuriFire and Integral FACP is to be carried out in accordance with Fig. 39 (L1 to L1, C1 to C1 etc.).
- The **identification sign** (EN 54-17) supplied with the XLM 35 **must** be attached outside on the ASD (next to the ASD rating plate).

6.6.5 OC outputs

The ASD criteria “Alarm” and “Fault” (all fault events) are available as OC outputs.

Parallel and feedback indicators or other consumers (e.g. relays) can be connected to the OC outputs.

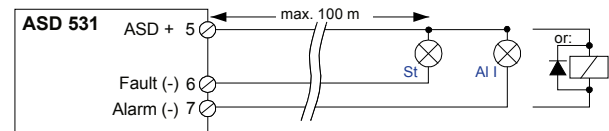

Fig. 40 Connecting the OC outputs



Notices

- When connecting inductive consumers (e.g. relays), a free-wheeling diode is to be installed directly at the consumer (**Fig. 40**).
- The outputs are 0-Volt switched and have a max. loading capacity of **100 mA** per output. The dielectrical strength per output is 30 VDC. The outputs are short-circuit-proof but not potential-free. Connection to the outputs affects the overall power consumption of the ASD 531.

7 Commissioning

7.1 General



Notices

The following points must be observed when commissioning the ASD 531:

- The ASD 531 is to be commissioned by trained and qualified personnel only.
- Prior to commissioning it is important to ensure that the entire sampling pipe has been laid correctly (junctions, sampling holes).
- If a maintenance sampling hole is provided as described in Sec. 4.4.4.4, it must be closed with adhesive tape or the maintenance clip.
- Prior to commissioning, an inspection of the mounting and installation must ensure that when the power supply is switched on there can be no damage to the ASD 531.
- Rewiring the device may be performed only when voltage is disconnected. Exception: Logging off additional modules XLM, RIM (see Sec. 7.3.8).
- Before switching on, the smoke detector and any additional modules in the detector box must be fitted and connected to the AMB 31 main board by means of the supplied flat cable. See also Sec. 6.3 and 6.4.
- Before switching on the ASD power supply, ensure that all fire incident controls and remote alerting from the ASD 531 are blocked or deactivated.
- Immediately before switching on the ASD 531 for the first time, remove the isolating strip from the lithium battery (AMB 31).
- System performance depends on the sampling pipe. Any extensions or modifications to the installation may cause functional faults. The effects of such changes must be checked. It is very important to adhere to the specifications in Sec. 4 (Planning). The “ASD PipeFlow” calculation software is available from the manufacturer.

The detector housing has to be opened for commissioning the ASD 531 (see Sec. 5.4.1).

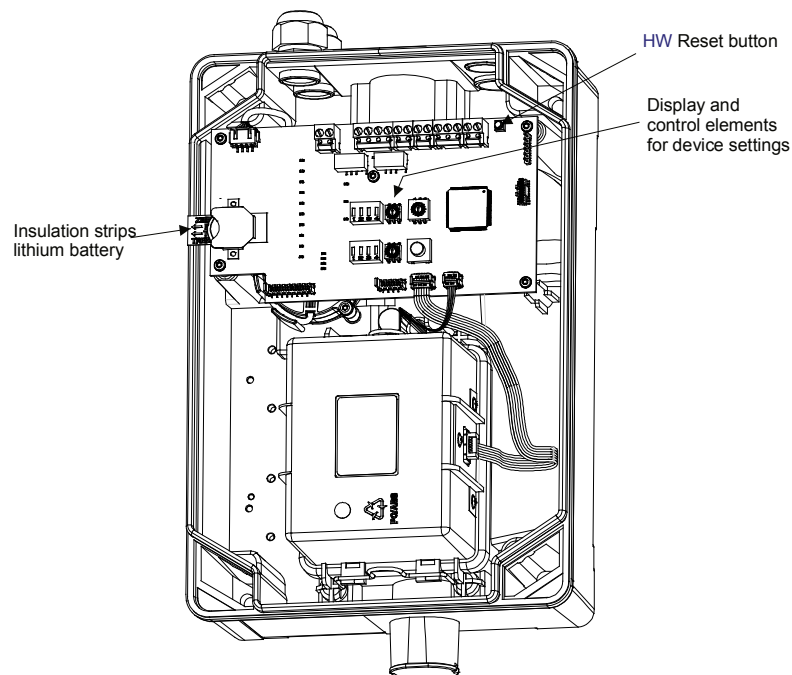

Fig. 41 Detector housing opened for commissioning

7.2 Programming

The ASD 531 has several switch positions that are configured with permanently assigned parameters:

- System limits according to EN 54-20 without “ASD PipeFlow”, Class A to C, rotary switch “Class”/“Holes” switch positions **A/1** to **F/C**;
- Switch positions for the settings based on application of “ASD PipeFlow”.

If the ASD 531 is operated in **BasiConfig**, only the corresponding switch position **A/1** to **F/C** as described in Sec. 4.4.4.1 are to be selected.

In systems where the sampling pipe planning was performed with the “ASD PipeFlow” calculation software, the response sensitivities of the smoke sensor calculated by “ASD PipeFlow” have to be programmed on the ASD 531 using the rotary switches “Class” & “Holes” as described in Sec. 4.3.1.1.

The following parameters can be modified on the AMB 31 (see Sec. 7.2.1):

- Smoke sensor alarm threshold;
- Air flow tolerance & delay time;
- Relay and state latching (alarm, pre-signal, fault);
- Alternative relay assignment (RIM 36).

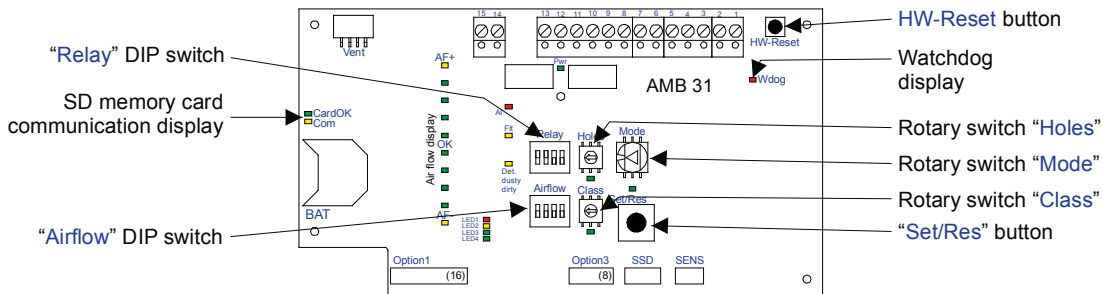

Fig. 42 Control and indicator elements on the AMB 31

7.2.1 Configuration options

7.2.1.1 Smoke sensor alarm threshold

The alarm threshold is set with rotary switches “Class” & “Holes” (see Sec. 7.3.2 and 7.3.3).

7.2.1.2 Air flow tolerance and delay time

The air flow tolerance and the delay time can be set on the “Airflow” Dip switch.

Switch 1	Switch 2	Air flow tolerance
OFF	OFF	±20% ①
OFF	ON	± 30%
ON	OFF	± 50%
ON	ON	±10% ②

Switch 3	Switch 4	Delay time
OFF	OFF	300 s (5 min) ①
OFF	ON	10 min
ON	OFF	20 min
ON	ON	10 s (test position) ③

Notices

① For normative systems the setting **±20% / 300 s** is required. Other values are **not** EN tested and may be used only after consulting with the manufacturer.

② The **window size ±20%** should in principle **not be undershot**. Smaller window sizes may be set only if, at the same time, the delay time of the airflow monitoring is increased to at least **10 min**. Due to the very high sensitivity of the airflow monitoring when the window size is below ±20% and the delay time is ≤ 300 s, the risk of false alarms due to airflow monitoring faults increases accordingly.

③ This setting may be used only for test purposes; it is not permitted in normal operation.

7.2.1.3 Relay and state latching / RIM 36 relay assignment

Relay and state latching is set on DIP switch “Relay” no. 1 to 3:

Switch 1 – 3	OFF	ON
1	No latching alarm	Latching alarm
2	No latching fault	Latching fault
3	No latching pre-signal	Latching pre-signal

On DIP switch “Relay” no. 4 you can toggle from the default relay assignment to the alternative relay assignment:

Switch 4	OFF = Default	ON = Alternative
RIM 36, Rel. 1	Pre-signal 1	Alarm
RIM 36, Rel. 2	Pre-signal 2	Alarm
RIM 36, Rel. 3	Pre-signal 3	Alarm or fault ①
RIM 36, Rel. 4	Smoke sensor: Dust / dirt / fault	Alarm or fault ①
RIM 36, Rel. 5	Sampling pipe; pipe blockage / pipe breakage Fan fault	Fault ①

Notice

① The following faults are included here:

- ⇒ Smoke sensor; dust, dirt, fault
- ⇒ Sampling pipe; pipe blockage, pipe breakage
- ⇒ General; fan, initial reset, undervoltage, clock

7.3 Starting up

The information on operation and display elements necessary for startup can be found in **Fig. 42**.



Notice

Before the ASD 531 is switched on, all the precautions required for operation as described in Sec. 7.1 must be fulfilled.

7.3.1 Commissioning procedure

The following illustrates the commissioning workflow for commissioning.

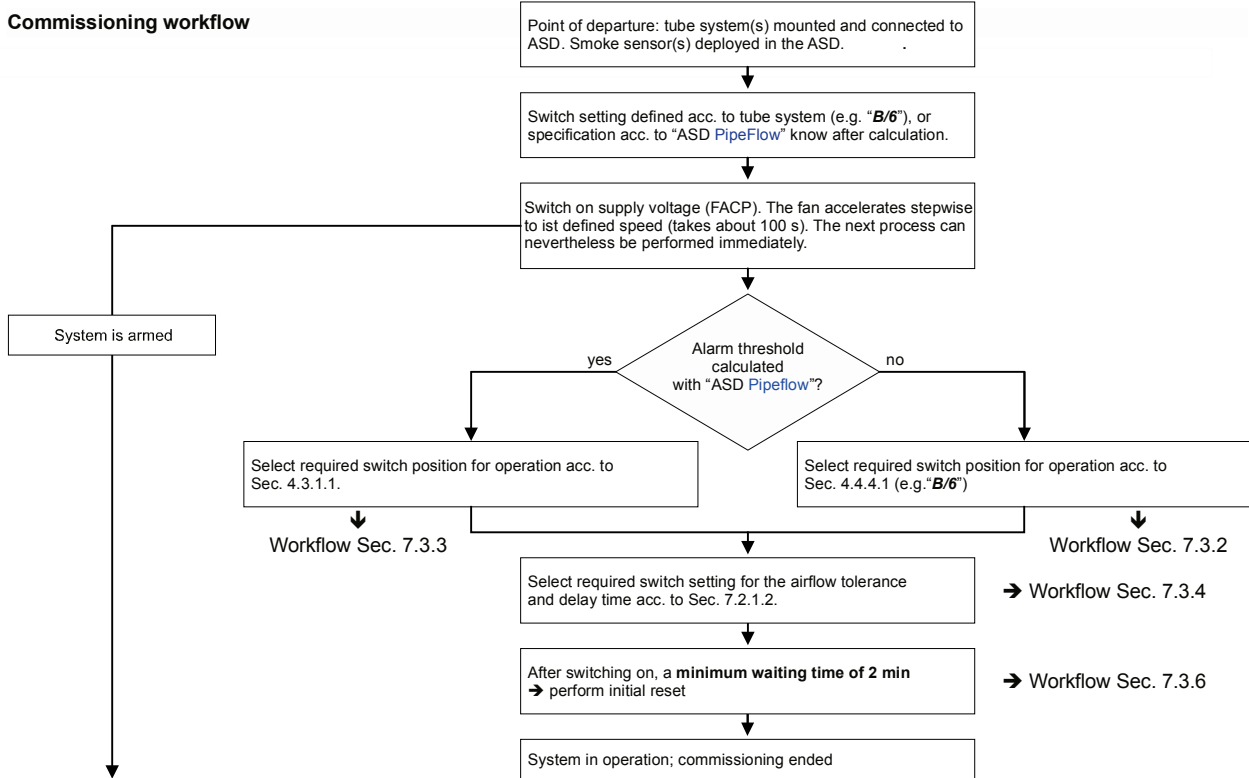

Fig. 43 Commissioning workflow

7.3.2 Setting the alarm threshold without "ASD Pipeflow" calculation

The following describes the procedure for setting the ASD 531 to one of the switch positions with fixed parameters **A/1** to **F/C**.

Example: The ASD 531 is to respond in compliance with EN 54-20, Class B. The sampling pipe is U-shaped with 3 sampling holes per sampling branch. According to Sec. 4.4.4.1 switch position **B/6** is to be selected.

Measure	Indicator ①	Procedure / remarks
(1) Turn rotary switch "Class" to position "B"	--	• Response behaviour compliant with EN 54-20, Class B
(2) Turn rotary switch "Holes" to position "6"	--	• Total sampling holes set to 6 (2 sampling branches each with 3 sampling holes)



Notice

① If there is a false or invalid entry (e.g. EN-Class A with 9 holes), LEDs "Class" and "Holes", begin to flash after a delay time. After a second delay time the ASD triggers a fault.

7.3.3 Setting the alarm threshold with “ASD Pipeflow” calculation

The following work flow describes the procedure when ASD 531 has to be set to an “ASD Pipeflow” calculated value.

Example: The ASD 531 is to respond in compliance with EN 54-20, class B. “ASD PipeFlow” calculated a value of 0.346%/m.

Measure	Indicator ①	Procedure / remarks
(1) Read the next more sensitive value from the table in Sec. 4.3.1.1.	--	• 0.337%/m (sensitivity 10 (A) in sensitivity range 2)
(2) Turn rotary switch “Class” to position “2”	--	• Sensitivity range 2 is set
(3) Turn rotary switch “Holes” to position “A”	--	• Sensitivity 10 is set



Notice

① If there is a false or invalid entry (e.g. EN-Class A with 9 holes), LEDs “Class” and “Holes”, begin to flash after a delay time. After a second delay time the ASD triggers a fault.

7.3.4 Setting the air flow tolerance and delay time

The following work flow describes the procedure for setting air flow tolerance and delay time of the ASD 531.

Example: ASD 531 is to trigger a fault if there is a deviation of $\pm 30\%$ after 20 min. Perform the settings as described in Sec. 7.2.1.2.

Measure	Indicator	Procedure / remarks
(1) Set Dip switch “Airflow”: Switch 1 on “OFF” Switch 2 on “ON”	--	• Air flow tolerance set to $\pm 30\%$
(2) Set Dip switch “Airflow”: Switch 3 on “ON” Switch 4 on “OFF”	--	• Delay time set to 20 min

Commissioning

7.3.5 Set date and time

In the highest directory of the SD memory card, a text file named **Date** must be created. The current time and date are to be entered in this file in the following format: **hh:mm:ss;dd.mm.yyyy**;

Example: 12:48:16;13.06.2015;

When the SD memory card is then inserted into the device, the time is automatically applied, after which the text file is deleted.

7.3.6 Initial reset

When commissioning the ASD 531, an initial reset is required. When this happens, the airflow monitoring is automatically aligned to the connected sampling pipe.



Notices

- In principle the initial reset should be carried out under “normal system conditions”, i.e. with any ventilation systems, air conditioning systems, etc., running in “normal operation”.
- If a maintenance sampling hole is provided, it must be closed with adhesive tape or the maintenance clip.
- The initial reset must be performed with normal ventilation for equipment monitoring of ventilated objects.
- When monitoring closed air-conditioning and ventilation ducts in which air velocities greater than 15 m/s are possible, the initial reset must be performed at 15 m/s.
- If there is an expansion, conversion, retrofitting or repair on the sampling pipe, an initial reset is imperative.
- An initial reset must be performed after the fan speed has been changed.
- After an FW upgrade, an initial reset is required only if expressly mentioned in the relevant firmware description.
- Before performing an initial reset after switching on the ASD 531, a **waiting time of at least 2 min** must be observed.

Measure	Indicator	Procedure / remarks
(1) Turn rotary switch “Mode” to position “0”	--	• Switch position initial reset
(2) Press key “Set/Res”	--	• Initial reset in progress
(3) Wait	Both middle LEDs of the air flow indicator are lit	• Initial reset completed
(4) Turn rotary switch “Mode” to position “1”	--	• Operation switch position
(5) Press key “Set/Res”	--	• Put ASD into operating state again

7.3.7 Isolate device

This function is used to place the ASD 531 in an isolated state. In this way test alarms can then be triggered on the ASD 531 without activating superordinate systems (FACP) (relays, OC outputs, XLM do not trigger). When the “Isolate” function is switched on, a fault is triggered on the ASD and forwarded to the superordinate centre. On the ASD the “Fault” LED is then continuously lit.

Isolate device

Measure	Indicator	Procedure / remarks
(1) Turn rotary switch “Mode” to position “2”	--	
(2) Press key “Set/Res”	Fault LED lit:	• Device is isolated • Device triggers fault

Revoke isolation

Measure	Indicator	Procedure / remarks
(1) Turn rotary switch “Mode” to position “1”	Fault LED lit:	
(2) Press key “Set/Res”	--	• Device is again in operation mode

7.3.8 Logging off additional modules XLM 35, RIM 36 and the SD memory card

The additional modules (XLM 35, RIM 36) and the SD memory card are automatically detected when the device is switched on; from that point onwards, they are monitored and fully functional. The SD memory card begins with data logging, recognisable on the flashing **Com** LED on the AMB. To eject the SD memory card or remove a subsequently fitted additional module (e.g. because it is not being used), the additional modules and SD memory card must first be logged off via the AMB 31 main board.

Notice		
	A time-out (approx. 15 s) is configured for the logoff procedure. During this time the additional modules can be electrically disconnected from the AMB 31 trouble-free or the SD memory card can be removed from the ASD. If no component is removed during that time (including removing the SD memory card), the additional modules are re-activated and data logging continues.	
Measure	Indicator	Procedure / remarks
(1) Turn rotary switch "Mode" to position "6"	--	
(2) Press key "Set/Res"	Airflow LED bar flashes	<ul style="list-style-type: none"> Start logoff procedure, duration approx. 15 s
(3) Electrically disconnect (ribbon cable) the relevant additional module from the AMB 31 within the logoff time (15 s) or remove the SD memory card.	Airflow LED bar flashes	<ul style="list-style-type: none"> If the module is not electrically disconnected from the AMB 31 within 15 s (including removal of the SD memory card), it is re-activated and data logging continues.
(4) Turn rotary switch "Mode" to position "1"	--	
(5) Press key "Set/Res"	--	<ul style="list-style-type: none"> Put ASD into operating state again

7.3.9 Switch device inactive

This function switches off the fan and sensor of the ASD 531. The ASD 531 is then no longer capable of an alarm. An inactive ASD triggers a fault and signals the superordinate unit (FACP) accordingly. On the ASD the "Fault" LED is then continuously lit.

Switch device inactive

Measure	Indicator	Procedure / remarks
(1) Turn rotary switch "Mode" to position "7"	--	
(2) Press key "Set/Res"	Fault LED lit:	<ul style="list-style-type: none"> Device is inactive Device triggers fault

Activate device again

Measure	Indicator	Procedure / remarks
(1) Turn rotary switch "Mode" to position "1"	Fault LED lit:	
(2) Press key "Set/Res"	--	<ul style="list-style-type: none"> Device is again in operation mode

7.4 Re-programming



Notice

The parameters are configured ex factory with default states and values so that the triggering properties comply with EN 54-20. Changing the parameters may result in non-compliance with EN 54-20. Adjustments and modifications to the ASD 531 may be carried out only by the manufacturer or by trained technicians.



7.4.1 Re-programming on the ASD 531

If a different switch position has to be selected within the present system limits (*A/1* to *C/C*), the re-programming is carried out as described in Sec. 7.3.1.

7.5 Download new firmware to the ASD 531

An FW upgrade is performed from the SD memory card. The file of the new FW must first be saved to the SD memory card in the highest directory (not in a sub-directory).

The workflow for upgrading the FW from the SD memory card is described below:

Notice		
 <p>The firmware download triggers a fault relay. When upgrading the FW on the ASD 531, it is therefore absolutely essential that fire incident controls and remote alerting on superordinate systems (FACP) are switched off beforehand.</p>		
Measure	Indicator	Procedure / remarks
(1) If the SD memory card is present, log it off via switch position 6 and remove.		<ul style="list-style-type: none"> See Sec. 7.3.8
(2) Copy the FW file to be transferred to the SD memory card and then re-insert the SD memory card in the ASD.		<ul style="list-style-type: none"> On the SD memory card to the topmost level (no sub-directory). Important: only one FW file may be saved.
(3) On the AMB 31, press and hold the “Reset” key and afterwards briefly press the “HW reset” button. After that release the “Reset” key.	Continuous lit LED1 (“Bootloader” indicator)	<ul style="list-style-type: none"> Continuously lit “Wdog” indicator Continuously lit “Fit” LED ASD triggers fault
(4) Transmission to the ASD 531 begins (takes approx. 10 s) → see also ①	LED1, LED2 and “Com” continuously lit	<ul style="list-style-type: none"> Transmission running
(5) FW upgrade is completed	LED1 – 4 flash (approx. 4 x)	<ul style="list-style-type: none"> Fault is reset ASD start phase running (LED “Fault” flashes about 60 s) ASD continues running with the previous installation-specific settings FW upgrade is completed
Notice		
 <p>Afterwards, normal data logging begins automatically on the still inserted SD memory card. If this is not wanted, the SD memory card must be logged off and removed after the FW upgrade (via switch position 6).</p>		
(6) After a waiting time of at least 2 min from point (5) an initial reset must be performed again. Attention: only necessary if expressly mentioned in the relevant firmware description.	According to Sec. 7.3.5	<ul style="list-style-type: none"> Observe the firmware description for the loaded FW According to Sec. 7.3.5

- ① If at step (4) the described display does not occur (reason: incompatible, third-party or no FW on the SD memory card), refer to the instructions of the concerned firmware description (**changes:** file designation of the FW; **compatibility:** required HW for this FW).

7.6 Measurements

The ASD supply voltage on terminals 1 and 2 must be checked (check also terminals 3 and 4 in the case of a redundant supply). The voltage must be between 17.6 and 27.6 VDC for a correctly set FACP voltage supply (not emergency current operation). The value depends on the line length. Once commissioning is completed, the measured voltage value is to be entered in the commissioning protocol (see Sec. 7.9).

With the conductor cross-section determined and installed as described in Sec. 4.9.2, this voltage range must always be available at the end of the electrical installation – i.e. at the ASD 531 – to ensure that the ASD 531 is able to operate fault-free (see also Sec. 4.9.2).



Notices

- If the measured value is outside the specified range, the ASD 531 may malfunction or even become damaged (over 30 VDC).
- Voltage values that are too low can be caused by insufficiently dimensioned conductor cross-sections or an incorrectly set FACP voltage.

7.6.1 Reading the airflow

The airflow is indicated on the LED bar (on the default installation) to the left of the control elements. If the two middle LEDs are lit, the airflow is 100% (airflow at the time of the initial reset). A green LED means deviation in the tolerance range according to Fig. 44. A yellow LED indicates airflow outside the tolerance. The sampling tube network must be cleaned (AF-) or inspected for pipe breakage (AF+).

	±20%	±30%	±50%	±10%	
AF+	>120%	>130%	>150%	>110%	
	116 - 120%	123 - 130%	138 - 150%	108 - 110%	
	111 - 115%	116 - 122%	126 - 137%	106 - 107%	
	106 - 110%	108 - 115%	113 - 125%	103 - 105%	
	101 - 105%	101 - 107%	101 - 112%	101 - 102%	
	99 - 95%	99 - 93%	99 - 88%	99 - 98%	100%
	94 - 90%	92 - 85%	87 - 75%	97 - 95%	
	89 - 85%	84 - 78%	74 - 63%	94 - 93%	
	84 - 80%	77 - 70%	62 - 50%	92 - 90%	
AF-	<80%	<70%	<50%	<90%	

Fig. 44 Airflow tolerance

Meaning: Value < 100% = direction pipe blockage / > 100% = direction pipe breakage



Notice

According to EN 54-20 a change in the airflow that is greater than ±20% must be reported as a fault. After an initial reset, the airflow shows 100% in the ASD 531 aspirating smoke detector when the sampling pipe is correct and clean. When switches 1 + 2 of the Airflow Dip switch are on **OFF**, any change in this value greater than ±20% – i.e. below 80% or above 120% – triggers a fault after the LS-Ü delay time of 300 s has expired.

7.7 Testing and checking

In addition to the sampling pipe checks set out in Sec. 7.1, the correct transmission of alarms (zone and line) on the FACP is to be checked by triggering faults or alarms on the ASD 531. These tests are to be entered in the commissioning protocol (see also Sec. 7.9).

Notice		
 <p>Block or deactivate fire incident control and remote alerting on the superordinate FACP.</p> <p>① Reset the ASD 531 between each check (preferably on the FACP, as a reset on the ASD does not reset the FACP). Likewise, after the tests the original state of the sampling pipe has to be restored (open taped sampling holes, close maintenance holes).</p>		
Test event	Procedure	Action
Checking the airflow monitoring ①	Tape up the sampling holes (adhesive tape); number depends on the pipe configuration	<ul style="list-style-type: none"> As soon as the resulting change in the airflow is exceeded by $\pm 20\%$ (can be checked via the airflow indication) the Fault LED begins to flash. When the LS-Ü delay expires (300 s), the ASD triggers a fault → fault on FACP.
Check alarm release ①	Apply smoke to maintenance sampling hole or sampling hole, see Sec. 7.7.1.	<ul style="list-style-type: none"> ASD triggers an alarm → alarm on FACP; check correct alarm transmission (zone/area triggering) on the FACP. If there are pre-signals they are also actuated

7.7.1 Checking the alarm release

When **commissioning** and after any changes (repairs) to the sampling pipe the alarm release **must** take place from the **last sampling hole** on the pipe branch. This tests the uniformity throughout the entire sampling pipe.

To test alarm actuation during regular **maintenance and service work**, the ASD 531 can be made to actuate on the **maintenance sampling hole**. Because the sampling pipes are continuously monitored for proper functioning, testing via the sampling pipe is normally not necessary. Once the test is completed, re-seal the maintenance sampling hole (using adhesive tape or maintenance clip).

If testing via the maintenance sampling hole is inadequate, testing can be carried out via the sampling pipe as follows:

- Point-by-point testing of the sampling holes**; apply smoke directly to individual or several sampling holes. Apiarist smoke or wax/joss sticks are suitable for this purpose.
- Area-wide testing of the sampling pipe**; area-wide testing of the sampling pipe using fire tests is reasonable and practicable only following EN 54-20.

Notice	
	<p>If genuine fire tests are to be carried out, the relevant local authorities (fire service) are to be consulted beforehand; the tests themselves are to be carried out by trained specialists (manufacturer) only.</p>

7.7.2 Test triggerings



Notice about test triggerings

Fire incident control and remote alerting must be blocked or deactivated on the superordinate FACP.



- ① Reset the ASD 531 between each check (preferably on the FACP, as a reset on the ASD does not reset the FACP).

Measure	Indicator	Procedure / remarks
(1) Test alarm Turn rotary switch "Mode" to position "5"	--	
(2) Press key "Set/Res" three times	Alarm LED is lit	<ul style="list-style-type: none"> ASD 531 triggers alarm → via relay or XLM to the FACP
(3) Turn rotary switch "Mode" to position "1"	Alarm LED is lit	
(4) Press key "Set/Res"	Alarm LED is lit	<ul style="list-style-type: none"> Put ASD into operating state again Alarm is not reset → reset from FACP ①
(5) Test fault Turn rotary switch "Mode" to position "3"	--	
(6) Press key "Set/Res" three times	Fault LED is lit	<ul style="list-style-type: none"> ASD 531 triggers fault → via relay or XLM to the FACP
(7) Turn rotary switch "Mode" to position "1"	Fault LED is lit	
(8) Press key "Set/Res"	Fault LED is lit	<ul style="list-style-type: none"> Put ASD into operating state again Fault is not reset → reset from FACP ①
(9) Test pre-signal Turn rotary switch "Mode" to position "4"	--	
(10) Press key "Set/Res" three times	Alarm LED flashes 2 Hz	<ul style="list-style-type: none"> ASD 531 triggers pre-signal → via relay or XLM to the FACP
(11) Turn rotary switch "Mode" to position "1"	Alarm LED flashes 2 Hz	
(12) Press key "Set/Res"	Alarm LED flashes 2 Hz	<ul style="list-style-type: none"> Put ASD into operating state again Pre-signal is not reset → reset from FACP ①

7.8 Filter monitoring operation

The following filter monitoring operations are available on the ASD 531 (see also Sec. 2.2.17):

- Filter monitoring On/Off;
- Change filter service life (in months, 2 – 20) / read out configured filter service life;
- Start filter replacement (also possible via the “Reset” key) / finish filter replacement (key “Reset”).

 Notice To prevent false alarms, the aspirating smoke detector is set to “Isolate” when filter replacement is active.		
Measure	Indicator	Procedure / remarks
(1) Filter monitoring On Turn rotary switch “Mode” to position “8”	--	“Filter monitoring off” is performed the same way as described under points (1) to (4) (LED 4 not lit).
(2) Press key „Set/Res“ for 10 s	LED 4 (green) is lit	• LED 4 indicates the filter monitoring “On” status
(3) Turn rotary switch “Mode” to position “1”	--	• Operation switch position
(4) Press key “Set/Res”	--	• Put ASD in operating state again
(1) Read out filter service life <u>Example: 6 months (Default)</u> Turn rotary switch “Mode” to position “9”	--	
(2) Press key “Set/Res”	LED bar of the air flow, 3 LEDs are lit and indicate the filter service life in months	• Pro LED displayed 2 months
(3) Turn rotary switch “Mode” to position “1”	--	• Operation switch position
(4) Press key “Set/Res”	--	• Put ASD into operating state again
(1) Change filter service life <u>Example: from 6 to 12 months</u> Turn rotary switch “Mode” to position “9”	--	
(2) Press key “Set/Res”	LED bar of the air flow, 3 LEDs are lit	• The filter service life of 6 months is indicated
(3) Press key “Set/Res” three times	LED bar of the air flow, 6 LEDs are lit	• The filter service life of 12 months is indicated
(4) Turn rotary switch “Mode” to position “1”	--	• Operation switch position
(5) Press key “Set/Res”	--	• Put ASD into operation state again
(1) Start filter replacement  Turn rotary switch “Mode” to position “8”	Prerequisite filter monitoring “On” (LED 4 is lit)	
(2) Press key “Set/Res”	--	<ul style="list-style-type: none"> • LED 1, status “Filter replacement started” • ASD smoke sensor is “isolated” • ASD triggers fault • LED “Fault” is lit • Filter service life set to “0”
(3) Turn rotary switch “Mode” to position “1”	--	• Operation switch position
(4) Press key “Set/Res”	--	• ASD is ready for filter replacement
(5) Open dust filter unit or filter box and replace dirty filter element with clean replacement filter element. Afterwards, close the dust filter unit or filter box.	--	• The date of the replacement must be entered on the new replacement filter element or in the commissioning log.
(6) Press key „Set/Res“ on ASD	--	<ul style="list-style-type: none"> • Filter replacement is completed • Fault is reset • Isolation is removed

- ① Also, when the ASD 531 housing is closed, the “Start filter replacement” function can be activated by means of the “Reset” key (provided the filter monitoring is activated). To do so, press the key **longer than 15 s** (attention: lamp test after 10 s). After 15 s the filter replacement is started and indicated by switching to the “Isolate” state (LED “Fault”). The filter replacement is completed by pressing the “Reset” key again.

7.9 Commissioning protocol

The ASD 531 ships with a commissioning protocol (fold-out) included in the scope of delivery. All of the measurements and tests carried out during commissioning and maintenance are to be entered on the protocol, which is then signed.



Notices

- When performing maintenance work or after certain other events, conclusions can be drawn concerning the commissioning state of the ASD 531 based on the commissioning protocol. The protocol also serves as a kind of life history of the ASD 531.
- The commissioning protocol is to be filled out conscientiously and fully and stored in the ASD 531. If required, a copy can be made and stored in the system dossier.

8 Operation



Notice

The following point must be observed when operating the ASD 531 aspirating smoke detector:

- System performance depends on the sampling pipe. Any extensions or modifications to the installation may cause functional faults. The effects of such changes must be checked. It is very important to adhere to the specifications in Sec. 4 (Planning). The “ASD PipeFlow” calculation software is available from the manufacturer.

8.1 Operation and display elements

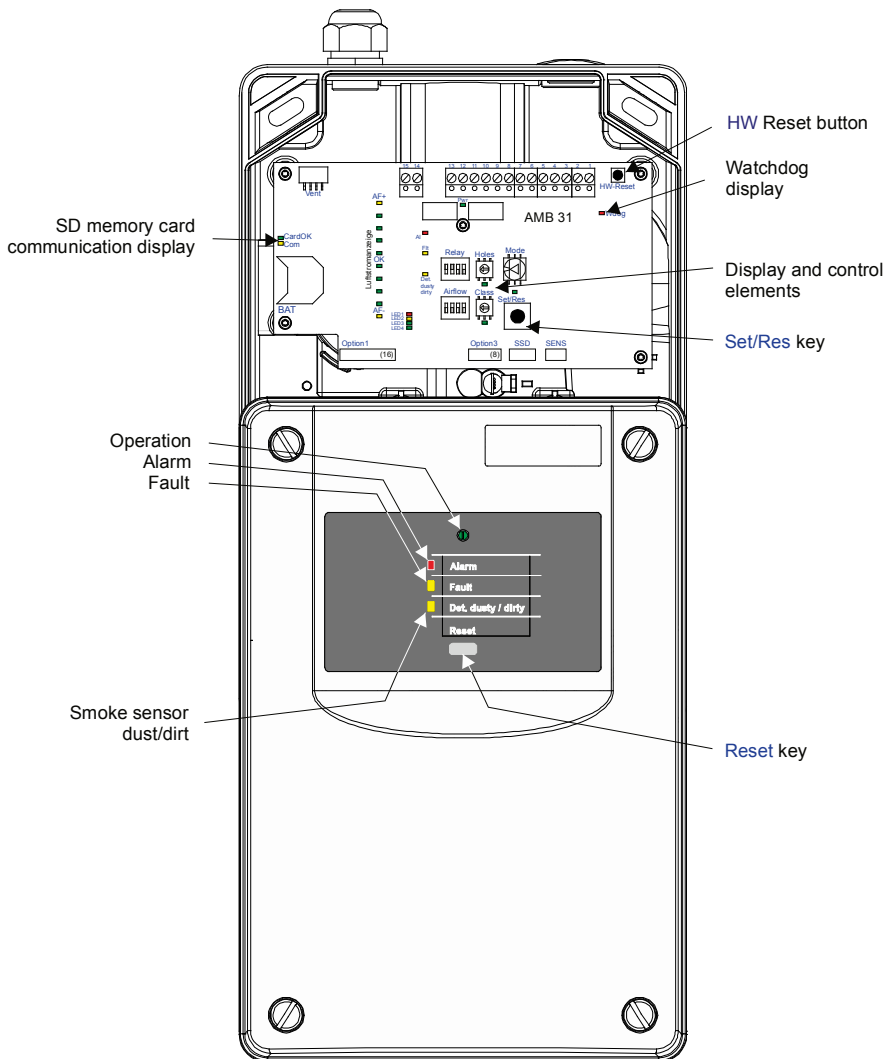

Fig. 45 View of the operation and display elements

The control unit has a “Reset” key for resetting triggered events (alarms/faults) directly on the ASD 531. If the “Reset” key is pressed longer than 10 s, all indicators flash together on the control unit as “lamp test”.

Three rotary switches and two DIP switches are inside the device on the AMB 31 main Board as well as three LEDs.

8.2 Functional sequence of operation

The operation of the ASD 531 aspirating smoke detector in normal mode (after commissioning) is limited to switching on/off or to resetting a triggered event (alarm/fault). Operation is generally via the FACP, with input of the “Zone On/Off” and “Reset” functions (on “Reset external” input of the ASD 531).

Events triggered on the ASD 531 can be reset locally using the “Reset” key on the control unit or by briefly actuating the “Reset External” input. The reset is possible only if the triggered event is no longer pending (e.g. smoke sensor no longer has smoke). The application of a continuous signal at the “Reset external” input also deactivates (switches off) the ASD 531 (see also Sec. 2.2.6 and 6.6.2).



Notice

A local reset does not reset a higher-order FACP. It may also happen that the reset in the ASD 531 triggers a fault in the superordinate line of the FACP.

To aid commissioning the ASD 531, there are three rotary switches and two DIP switches inside the device on the AMB 31 main board.

These elements are used when commissioning the ASD 531. Device settings for pre-defined system limits can be called up. These pre-defined positions are stored with normative values for response sensitivity, airflow monitoring (LS-Ü) and pipe configuration. They also contain positions which allow deviations from the normative limits with regard to airflow monitoring.

8.3 Rotary switch “Mode” switch positions

The switch settings listed below can be called up on the AMB 31.

Pos.	Purpose	Meaning / Procedure ①
0	Initial reset	see Sec. 7.3.6
1	Operation position	--
2	Isolate device	see Sec. 2.2.12.1 / 7.3.7
3	Test trigger fault	see Sec. 7.7.2
4	Test trigger pre-signal	see Sec. 7.7.2
5	Test trigger alarm	see Sec. 7.7.2
6	Log off optional module	see Sec. 7.3.8
7	Device inactive	see Sec. 7.3.9
8	Filter monitoring On/Off, filter replacement	see Sec. 7.8
9	Read out / change filter service life	see Sec. 7.8
A – F	Reserve	--



Notice

① The table lists only the available switch positions. A detailed description of the operator functions (input procedure) can be found in the relevant section (“Meaning / Procedure” column).

When the “Mode” rotary switch is turned to a new position, it must be confirmed within 5 s with the “Set/Res” key. If not, another 5 s delay time occurs (“Mode” LED flashes). If no confirmation occurs after this time, the ASD triggers a rotary switch fault.

8.4 Reset

The ASD 531 can be reset after a triggered event by:

- Pressing the “Reset” pushbutton locally on the ASD or
- Briefly actuating the “External reset” input on the ASD.



Notices

- For a local reset, the “Mode” rotary switch must be set to **Pos 1**.
- Resetting can be triggered only after an event, but only if the criterion that resulted in the event trigger is back in its normal state (e.g. smoke level in the smoke sensor is once again below the trigger threshold, or a fault event is rectified). As a result of the reset, the ASD 531 continues to run “normally” and the fan does not stop.
- Local resetting (“Reset” key) does not reset a superordinate FACP. It may also happen that the reset in the ASD 531 triggers a fault in the superordinate line of the FACP.

8.5 Displays

8.5.1 Displays on the control unit

Several LEDs on the control unit indicate the current status of the ASD 531. The following table lists the states for the ASD 531.

Function / state	Indicator			
	Operation	Alarm	Fault	Det. dusty Det. dirty
	green	red	yellow	yellow
System Off (no voltage)				
System inactive (Reset external)	On		½ s T	
Smoke sensor Off (from FACP)	On		½ s T	
Quiescent state	On			
Pipe blockage/pipe breakage, delay time running ①	On		1 s T	
Pipe blockage/pipe breakage, fault triggered	On		On	
Fan tachometer signal missing	On		On	
Fault triggered	On		On	
Pre-signal 1	On	2 s T		
Pre-signal 2	On	1 s T		
Pre-signal 3	On	½ s T		
Alarm	On	On		
Smoke sensor filter fault	On			2 s T
Smoke sensor dusty	On			1 s T
Smoke sensor dirty	On			½ s T
Smoke sensor fault	On			On
Lamp test (press “Reset” key 10 s)	On	1 s T	1 s T	1 s T



Notice

① No fault triggered (triggers only after delay time has expired → “Fault” continuously lit).
T = flashing display; ½ s cycle / 1 s cycle / 2 s cycle

8.5.2 Indicators on the AMB 31 main board

Various LEDs with the following meaning are on the AMB 31 main board (see also **Fig. 45**):

- LED “Class” and “Holes” flash = invalid constellation of rotary switches “Class” and “Holes”;
- LED “Mode” = various functions (see Sec. 0);
- LED “WDog” = watchdog display (processor not running → ASD has triggered a fault);
- LED “CardOk” = SD memory card present;
- LED “Com” = communication with the SD memory card.
- LED 2 (yellow) flashing = filter replacement started;
- LED 4 (green) continuously lit = filter monitoring “On”.

8.5.3 SD memory card operation

The SD memory card is automatically detected when the device is switched on and when the card is inserted. From then on it is monitored. Data logging begins automatically after approx. 10 s.



Notices

- Only industrial SD memory cards tested and approved by the manufacturer may be used (see Sec. 12.1). The use of a consumer SD memory card is to be avoided – this can lead to data loss or destruction of the SD memory card and faults on the ASD.
- Inserting the SD memory card: Before using the SD memory card, make sure it is blank (file interpretation).
- Removing the SD memory card: To avoid data loss, log off the SD memory card on the AMB 31 (**Mode** rotary switch, position 6) before removing (see Sec. 7.3.8).

The SD memory card is inserted with the contact side facing toward the LMB circuit board and pushed into the holder until it snaps into place. Pressing the SD memory card again releases the locking mechanism and the SD memory card can then be removed from the holder.

The meaning of the “CardOk” and “Com” associated LEDs is described Sec. 8.5.2.

8.5.3.1 Data logging on the SD memory card

Smoke level and airflow values: The smoke level and airflow values as well as the current status of the sampling tube network for each sensing tube are written to the SD memory card every second and saved in **Log-files** (*.xls file). After 28,800 entries (corresponds to 8 hours) a new **Log-File** is generated automatically. A total of 251 **Log-Files** (L000.xls to L250.xls) can be generated for long-term logging. After the last **Log-File** the oldest one (L000.xls) is overwritten. The 251 **Log-Files** cover data logging for 83 days. The **log files** can be opened in Excel and the data processed with the diagram assistant to create charts.

Events: All events occurring in the ASD 531 are written to the **Event-Files** (*.aev file). After 64,000 events a new **Event-File** is created automatically. A total of 10 **Event-Files** (E000.aev to E009.aev) can be generated for long-term logging. After the last **Event-File** the oldest one (E000.aev) is overwritten. The 10 **Event-Files** are sufficient to log over 640,000 events. The **Event-Files** can be opened with a text editor. Please refer to Sec. 8.5.4 for the interpretation of the events.

8.5.4 Reading out the event memory

As soon as an SD memory card is used in the device (even when the SD memory card is present during device startup), the content of the event memory is copied to the SD memory card.

8.5.4.1 Interpretation of the event memory

One event per line is listed in the **Event-File**. Besides the date and time of the event, a 2 x 3 digit code is listed. The first 3 digits (**group**) specify the event group as described in Sec. 8.5.4.2 (**000 = G00**). The remaining 3 digits (**Event**) specify the event code as described in Sec. 8.5.4.3.

8.5.4.2 Event groups

Event group	Purpose
G00	General events, part 1 (ASD On/Off, inactive, start initial reset, smoke sensor on/off from FACP)
G01	General events, part 2 (time, clear event memory)
G04	General events, part 4 (reset events)
G10	Smoke sensor events (alarm, dust/dirt, pre-signals)
G11	Smoke sensor faults, part 1 (communication to ASD)
G12	Smoke sensor faults, part 2 (smoke sensor events)
G13	Isolate smoke sensor (On/Off, test results)
G14	Test trigger from <i>BasiConfig</i>
G16	Smoke sensor filter faults, filter replacement
G30	Airflow monitoring sampling pipe (pipe blockage, pipe breakage, LS-Ü parameters, air flow sensor def./lacking)
G50	Fan faults (tacho signal, regulator, current consumption)
G60	Initial reset faults (various initial reset parameters, initial reset time-out , airflow too low)
G70	RIM faults
G71	XLM faults
G73	Memory card faults
G80	AMB faults (undervoltage, clock)
G81	Operating system faults

8.5.4.3 Event codes within event groups

G00, general events, part 1	
001	Switch on ASD (supply voltage)
002	Initial reset carried out (ASD)
004	ASD switched off (inactive, via "External reset")
008	ASD switched on (via "External reset")
016	Smoke sensor switched off from FACP (SecuriFire – Integral)
064	Smoke sensor switched on from FACP (SecuriFire – Integral)
G01, general events, part 2	
001	Date, time set
016	Event memory deleted
G04, general events, part 4, reset results	
001	Key
002	SecuriLine
008	External

→→

Operation

Continuation:

G10, smoke sensor events	
001	Alarm
002	Dust
004	Dirt
008	Pre-signal 1
016	Pre-signal 2
032	Pre-signal 3
G11, smoke sensor faults, part 1	
001	Communication ASD <> smoke sensor
002	Unknown smoke sensor type
004	Response sensitivity too low
008	Invalid parameters
G12, smoke sensor faults, part 2	
001	Measuring chamber
002	Temperature
004	Supply voltage
008	EEPROM access error
016	EEPROM invalid data
032	Manufacturing
G13, isolate smoke sensor	
001	Isolated alarm
002	Isolate switched on
004	Isolate switched off (normal operation)
008	Isolated pre-signal 1
016	Isolated pre-signal 2
032	Isolated pre-signal 3
G14, test trigger from <i>BasiConfig</i>	
001	Alarm test
002	Fault test
004	Pre-signal 1 test
008	Pre-signal 2 test
016	Pre-signal 3 test
G16, smoke sensor filter faults, filter replacement	
001	Smoke sensor filter fault (service life exceeded)
016	Smoke sensor filter replacement started
G30, airflow monitoring sampling pipe	
001	Pipe blockage sampling pipe
002	Pipe breakage sampling pipe
004	Invalid <i>LS-Ü</i> parameters
008	Air flow sensor defective / missing
G50, fan faults	
001	Tacho signal missing
002	Motor regulation outside range
G60, initial reset faults	
004	Initial reset <i>time-out</i>
008	Invalid parameters for initial reset
G70, RIM faults	
001	RIM fault, missing or defective
064	Incompatible RIM fault
128	RIM fault, too many RIMs
G71, XLM faults	
016	XLM fault, missing or defective
064	XLM fault, too many XLMs
G73, SD memory card faults	
001	SD memory card fault, missing or defective

G80, AMB faults	
001	Air pressure sensor fault
002	Temperature sensor fault
004	Undervoltage fault
008	Clock fault
016	Rotary switch fault
G81, Operating system faults	
001	Fault, mailbox unknown error
002	Fault, mailbox error (memory is full)
004	Fault, various error
008	Fault, timer error
016	Fault, mailbox storage cannot be approved
032	Fault, buffer overflow option module
064	Fault, EEPROM error

8.5.5 Operation and displays on the XLM 35

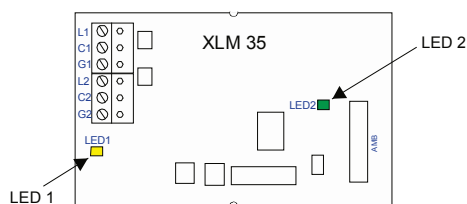

Fig. 46 XLM 35 operation and display

The two LEDs on the XLM 35 indicate the communication state.

LED 1 (yellow)	State XLM 35 <-> addressable loop (lights only if supply from AMB is OK)
Not lit	No addressable loop voltage
Continuously lit	Addressable loop voltage OK, no communication XLM <-> Line
Flashes (normal operation)	Communication XLM <-> Line OK
LED 2 (green)	State ASD 531 <-> XLM 35
Not lit	No power supply from AMB 31
Flashes (normal operation)	Supply from AMB 31 OK, communication XLM <-> ASD OK

9 Maintenance and service

9.1 General



Notices

- Maintenance and service work on fire alarm systems are subject in part to country-specific laws and directives.
- Maintenance and service work may be performed only by persons trained and authorised by the manufacturer of the ASD 531.
- Depending on application, the ASD 531 must be serviced at least once a year by the manufacturer or by qualified personnel authorised and trained to do so by the manufacturer. If required (e.g. significant dirt hazard), the service interval is reduced to guarantee functional reliability. If filter boxes and/or filter units are used, the service life of the filter inserts play a role in the service interval. Depending on the level of dust and dirt in the object, filter service may vary greatly. The optimum filter service life is to be determined on site on a case by case basis. When using the filter monitoring according to Sec. 2.2.17, the filter service life is set to 6 months by default, but it can be parameterised from 2 to 20 months.

The operator is obligated to conclude a service agreement with the manufacturer or with an installer authorised by the manufacturer if the operator does not have the required service personnel trained by the manufacturer.

The statutory national directives (DIN VDE 0833-1, Cantonal Fire Insurance Union) governing maintenance must be observed.

Servicing, maintenance or inspection work on the ASD 531 may be necessary after an event (fire, fault).

If a detector housing has to be replaced due to a defect, the new ASD 531 is to undergo the same procedure as a first-time commissioning (initial reset required). All the customer-specific configurations have to be carried out once again on the replaced ASD 531.

For maintenance work and function checks, observe the relevant information set out in Sec. 9.3 below.

If filter-boxes or dust filter units are installed in applications with a high level of soiling risk, a "simplified" maintenance can be performed on the filter-boxes or dust filter boxes as described in Sec. 9.3.1.

9.2 Cleaning

Clean the detector housing with a **non-aggressive** cleaning agent (e.g. soap suds or similar).

Normally only the sampling holes need to be cleaned on the sampling pipe tube network. In applications where dirt is a major issue, it may be necessary to clean inside the sampling pipe (blow out with compressed air or nitrogen). Only **non-aggressive** cleaning agents may be used when cleaning the sampling pipe (e.g. soap and water or similar).



Notice

Aggressive cleaning agents (such as solvents, pure petrol or other alcohol-based agents) must not be used for cleaning.

9.3 Maintenance checks and function checks



Notice

To avoid triggering fire incident controls, remote alerting and extinguishing areas when carrying out maintenance work, it is **essential** to block or switch off those systems beforehand.

For maintenance and function checks, carry out the following points:

1. Block or switch off fire incident control and remote alerting on the superordinate FACP.
2. Check that the supply voltage on the FACP is set in compliance with maintenance instructions for the control panel.
3. Check that the sampling pipe inlet is correctly seated on the detector housing (ASD 531).
4. Check the air outlet for any dirt or dirt and clean if necessary.
5. If the ASD 531 is used for equipment monitoring and plug-in transitions from rigid to flexible pipe sections are in place, check that the transitions are correctly seated (no leakage).
6. Open the cover of the detector housing. Carry out the following measurements:
 - Measure the operating voltage on terminal 1 (+), 2 (-) → 17.6 to 27.6 VDC.
 - Read out the airflow value on the airflow indicator (see Sec. 7.6.1) and compare with the commissioning protocol. If there is a deviation of more than half the set sensitivity (see examples ① and ②), check the sampling pipe as follows:
 - An **increase** in the value (more than 100%) tends to indicate **pipe breakage** → check the sampling pipe for leaks (junctions, fittings, etc.)
 - A **decrease** in the value (less than 100%) tends to indicate a **pipe blockage** → check the sampling pipe for pipe blockage, clean as described under **Item 9** or **Item 10**.
- ① Set **LS-Ü** sensitivity = ±20% (default); half of that = ±10%. The sampling pipe should therefore be checked if the value is below 90 % or above 110 %.
- ② Set **LS-Ü** sensitivity = ±50% (non-compliant with EN 54-20), half of that = ±25%. The sampling pipe should therefore be checked if the value is below 75% or above 125%.
7. Switch off the ASD (pull terminal block 1/2 and if necessary 3/4 on the AMB 31). After disconnecting the ribbon cable from the smoke sensor, carefully remove the sensor from the ASD.
8. Use a soft, dry paintbrush to clean the inside of the smoke sensor chamber and the insect protection screen. Oil-free compressed air or nitrogen can also be used for cleaning.



Notice

Do not use compressed air either to blow out or open the smoke sensor. Improper handling can affect the response characteristics. Only the manufacturer is authorised to clean dirty smoke sensors. The smoke sensors are monitored for dust and dirt; their states are displayed on the control unit. If required the smoke sensor must be replaced.

After cleaning the smoke sensor chambers, re-insert the smoke sensor into the ASD.



Continuation:

9. If it is necessary to clean the sampling pipe as indicated under **Item 6**, carry out the following measures (possibly also according to **Item 10**):
- Clean all sampling holes in the entire sampling pipe tube network. Tobacco pipe cleaners can be used for this purpose.
 - If the sampling holes are not accessible, the entire sampling pipe tube network can be blown out from the detector housing using oil-free compressed air or nitrogen. This is done via the manual ball valve or from the loosened screw-junction piece (pipe connection) of the last accessory part in the direction of the sampling pipe network.



Notice

Blowing out from inside the smoke sensor chamber (through the fan) can damage the fan and is therefore not permitted.

- Open the accessory parts (water retaining box, filter-box/filter unit, detector boxes) where fitted, and clean with a soft dry paintbrush. Oil-free compressed air or nitrogen can also be used for cleaning. Replace the filter element in the filter-box or filter unit. Close all the accessory parts again after cleaning.
 - After cleaning the sampling pipe, re-connect it correctly to the ASD 531.
10. In applications where dirt is a major issue, it may be necessary to clean the air-flow sensor. For this purpose (see Sec. 9.4.3) take it out of the holder and clean with a soft, dry brush → **Caution: Do not clean or touch the sensor surface with your fingers.** Then re-insert the air-flow sensor as indicated in Sec. 9.4.3 → make sure it is correctly seated inside the holder.
11. Switch the ASD back on again and wait until the fan has reached its optimal speed (at least 2 min).
12. Check fault triggering, alarm release and correct alarm transmission to the FACP as described in Sec. 7.6.1. Log the completed tests in the commissioning protocol.
13. Read the airflow value again. If the values set out under **Item 6** are still outside the tolerance range, the airflow monitoring will have to be readjusted (initial reset as described in Sec. 7.3.5).



Notices

- A new initial reset is not usually necessary after cleaning work on the sampling holes (cleaning restores the commissioning state). If an initial reset is necessary nonetheless after the work set out under **Item 13**, it may **only** be carried out once it has been ensured that all possible measures for cleaning the sampling pipe have been carried out (incl. a new filter element).
- If an initial reset is carried out with blocked sampling holes, there is the danger that insufficient air samples or no air samples will be aspirated and hence the ASD 531 can no longer trigger an alarm.

14. If maintenance or repair work was carried out on the ASD 531 (including the sampling pipe) as a result of servicing check, a new initial reset may be necessary (see Sec. 7.3.5).
15. All measurements and tests carried out are to be entered and signed for in the commissioning protocol. The completed commissioning protocol is to be stored with the ASD. If required, a copy can be made and stored in the system dossier.
16. After completion of the servicing check, close the detector housing once again.

9.3.1 Filter replacement on dust filter units

If a "Filter fault (service life exceeded)" fault trigger occurs when filter monitoring is activated and after expiry of the configured filter service life, the filter element in a filter-box or dust filter unit must be replaced. See also Sec. 7.8.

To replace the filter element, the "Filter replacement" function must be activated on the ASD (via the "Reset" key or *BasiConfig*). When filter replacement is activated, the aspirating smoke detector is set to the "Isolate" state. This insures that during the replacement work falling dust particles from the filter element do not cause a false alarm. After the filter has been replaced, the "Filter replacement" procedure is completed by pressing the "Reset" key on the ASD. This cancels the "Isolate" state and resets the fault on the ASD. The "Filter service life" monitoring is restarted at 0 (see Sec. 7.8).

9.4 Replacing units



Notice

Defective units such as the AMB 31, smoke sensor, air flow sensor and fan can only be replaced in the de-energised state (with terminal block 1/2 and possibly 3/4 unplugged from the AMB 31).

9.4.1 Replacing the smoke sensor

The smoke sensor must be replaced if defective or if there is a dirt message.

To replace the smoke sensor proceed according to Sec. 6.3.

9.4.2 Replacing the aspirating fan unit

To replace the AFU 32 Aspirating Fan Unit, the AMB 31 main board must be removed. To do so, carefully unplug all the internal cable connections (including fan connection). The plug-in terminals 1 to 21 do not necessarily have to be unplugged. After removing the retainer screws on the AMB 31 using a **Torx T10 screwdriver**, the AMB 31 can be lifted up toward the cable in-feeds and the retaining screws on the aspirating fan unit are then accessible. To dismantle the aspirating fan unit, remove the two screws **A** using a **Torx T15 screwdriver** (see Fig. 47).

To mount the new fan, proceed in the reverse sequence. **Important:** Before screwing on the replacement fan, the supplied spacers must be inserted into their fastening holes.

The connection cable must be placed in **B**.



Notice

After replacing the aspirating fan unit, it is imperative to carry out a new initial reset (see Sec. 7.3.5).

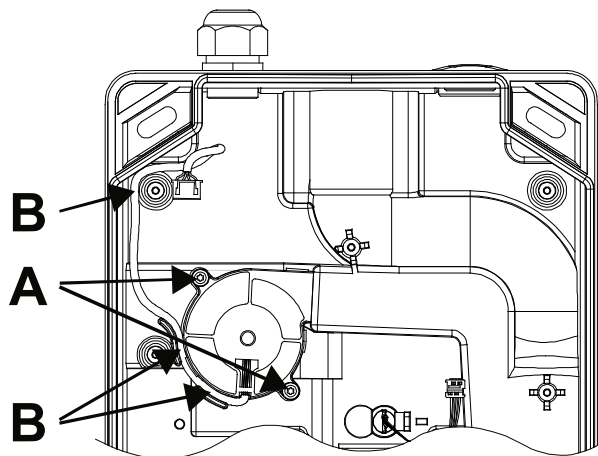

Fig. 47 Removing the aspirating fan unit

9.4.3 Replacing the air flow sensor



Notices

- When removing and mounting the air flow sensor, make sure that the sensor element is not damaged (i.e. does not break). Do not pull on the connection wires.
- After replacing an air flow sensor (new sensor), it is imperative to carry out a new initial reset (see Sec. 7.3.5).

Remove connector **A** of the air flow sensor on the AMB 31. To remove an air flow sensor, gently press lock tab **B** towards the smoke sensor chamber. The air flow sensor can then be carefully pulled out of its holder by gripping tab **C** with thumb and index finger → **Attention: do not pull on the connection wires of the air flow sensor**. To install the new air flow sensor proceed in the reverse sequence. It is important to note the installation position (anti-twist safeguard) of the air flow sensor and that it is correctly seated in its holder. To do so, press the air flow sensor by its grip tabs **C** towards the housing base until the lock tab snaps over the air flow sensor → **Attention: do not press on the connection wires of the air flow sensor**.

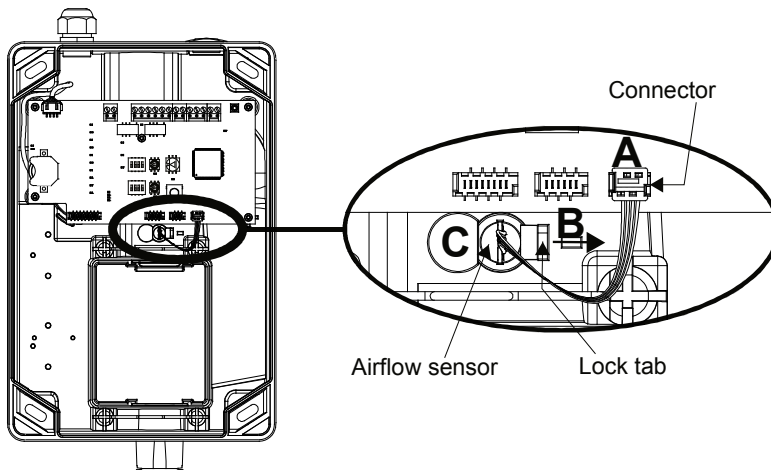

Fig. 48 Removing the air flow sensors

9.4.4 Replacing the AMB 31 Main Board

To replace the AMB 31 Main Board, unplug all the plug-in terminals with installation wires. Likewise, all internal cable connections (ribbon cable connectors) must also carefully be unplugged. Once the 5 fastening screws of the AMB 31 have been removed using a **Torx T10 screwdriver**, the AMB 31 can be replaced. To install the new AMB 31, proceed in the reverse sequence.





Notices

- When connecting the new AMB 31, take note of the correct assignment of the terminals and ribbon cable connectors (see **Fig. 5**).
- After replacing the AMB 31 it is imperative to carry out a new initial reset (see Sec. 7.3.5). Likewise, all customer-specific configurations and project-specific settings from the "ASD PipeFlow" configuration software must be carried out once again. To do so, proceed according to Sec. 7.3.1.

9.5 Disposal

The ASD 531 aspirating smoke detector and its packaging consist of recyclable material that can be disposed of as described in Sec. 9.5.1.

9.5.1 Materials used

Recycling

All raw materials and other materials used in the ASD 531 and all the technologies used in manufacturing are ecologically and environmentally friendly in compliance with ISO 14000.

All waste resulting from assembly (packaging and plastic parts) can be recycled and should be disposed of accordingly.

Devices, sampling pipes or parts thereof that are no longer used should be disposed of in an environmentally-friendly manner.

The manufacturer of the ASD 531 is obliged to take back any devices and sampling pipes that are defective or no longer used, for eco-friendly disposal. For this purpose the manufacturer has implemented a monitored and approved disposal system. This service is available worldwide at cost price.

Materials used in the ASD 531:

Detector housing	PC / ABS
Smoke sensor SSD 31	Lexan (PC)
Fan housing / fan wheel	PBTP / PBTP
Fan electric motor	PU / Cu / barium ferrite powder
Circuit boards, general	Epoxy resin hard paper
Soldering process	Environmentally-friendly manufacturing compliant with RoHS
Foil on control unit	PE
Sampling tubes	ABS / PA
Fittings	ABS / PA
Clips	PA
ABS adhesives	ABS / solvent MEK (methyl, ethyl, ketone)



Notice with PVC plastics

Because PVC plastics when burned produce toxic, corrosive and environmentally damaging combustion products, the use of PVC is not permitted in many applications. The relevant construction regulations must be observed.

Ecology:

PVC plastics cannot be manufactured and disposed of without environmental impact. The recycling of PVC is possible only up to a limited degree. Please refer to the danger notice above.

Sampling tubes	PVC, see danger notice above
Fittings	PVC, see danger notice above
PVC adhesives	PVC / solvent tetrahydrofurane, cyclohexanone

10 Faults

10.1 General

When troubleshooting, do not make any on-site modifications to the printed circuit boards. This applies in particular to replacing or changing soldered components. Defective printed circuit boards and units are to be completely replaced by the corresponding spare part according to Sec. 12.1. No repairs of defective printed circuit boards and units will be undertaken by the manufacturer. It is nevertheless possible to return complete ASD devices to be checked if there is a complaint or if a guarantee is the issue.



Notice

Printed circuit boards are to be replaced or changed only by trained and qualified personnel. Handling is permissible only when the measures for protection against electrostatic discharge are observed and heeded.

10.2 Warranty claims

Failure to observe the aforementioned rules of conduct will invalidate any warranty claims and manufacturer's liability for the ASD 531.



Notices

- Repairs to the device or parts thereof are to be carried out only by personnel trained by the manufacturer. Non-observance of this regulation results in the invalidation of warranty claims and the manufacturer's liability concerning the ASD 531.
- All repairs and troubleshooting measures are to be documented.
- The ASD 531 must undergo a function check following a repair or troubleshooting measure.

10.3 Finding and rectifying faults

10.3.1 Fault states

With the aid of the event memory and the relevant event code display (can be called up from the SD memory card), it is possible to localize the error in the event of a fault. The table below lists the event codes for possible fault states and how to rectify them. A list of all the event codes is provided in Sec. 8.5.4.3.

Notice

Multiple codes: If there are multiple events for any given event group, the display readings are added together.
Example: Display **012** = event code **004** and **008**.

G10, smoke sensor events			
Code	Meaning:	Check:	Possible causes and remedy:
002	Dust	Check smoke sensor chamber, sampling pipe and filter-box/filter unit for dust deposits	<ul style="list-style-type: none"> Clean interior of smoke sensor chamber and insect protection screen Check and clean sampling pipe and, if necessary, filter-box / filter unit. Replace smoke sensor
004	Dirt	Check smoke sensor chamber, sampling pipe and filter-box/filter unit for dirt deposits	<ul style="list-style-type: none"> Clean interior of smoke sensor chamber and insect protection screen Check and clean sampling pipe and, if necessary, filter-box / filter unit. Replace smoke sensor
G11, smoke sensor faults, part 1			
Code	Meaning	Check:	Possible causes and remedy:
001	Communication ASD <-> smoke sensor	Ribbon cable connection AMB, smoke sensor	<ul style="list-style-type: none"> Ribbon cable incorrectly attached or defective → check, replace. Smoke sensor defective → replace. AMB defective → replace
002	Unknown smoke sensor type (production fault)	Smoke sensor	<ul style="list-style-type: none"> Replace smoke sensor
008	Invalid parameters (production fault)	Smoke sensor	<ul style="list-style-type: none"> Replace smoke sensor
G12, smoke sensor faults, part 2			
Code	Meaning	Check:	Possible causes and remedy:
001	Measuring chamber	Smoke sensor	<ul style="list-style-type: none"> Smoke sensor defective → replace.
002	Temperature	ASD ambient temperature Smoke sensor	<ul style="list-style-type: none"> Adhere to ambient temperature specifications. Smoke sensor defective → replace
004	Supply voltage	Check ASD operating voltage AMB, smoke sensor	<ul style="list-style-type: none"> Set operating voltage correctly AMB defective → replace Smoke sensor defective → replace
008	EEPROM access error	Smoke sensor	<ul style="list-style-type: none"> Smoke sensor defective → replace
016	EEPROM invalid data	Smoke sensor	<ul style="list-style-type: none"> Smoke sensor defective → replace
032	Manufacturing	Smoke sensor	<ul style="list-style-type: none"> Smoke sensor defective → replace
G16, smoke sensor filter faults			
Code	Meaning	Check:	Possible causes and remedy:
001	Filter fault (service life exceeded)	Ⓢ Check of whether the filter service life is correctly configured for the object-specific ambient dust and soiling load.	<ul style="list-style-type: none"> Insert filter element If Ⓢ applies → increase filter service life

→→

Faults

Continuation:

G30, airflow monitoring sampling pipe			
Code	Meaning	Check:	Possible causes and remedy:
001	Pipe blockage	Sampling pipe, air outlet on the ASD, LS sensor	<ul style="list-style-type: none"> • Check sampling pipe for pipe blockage (sampling holes, air outlet) • Check and clean filter-box/filter unit • Check and clean LS sensor
002	Pipe breakage	Sampling pipe, LS sensor	<ul style="list-style-type: none"> • Check sampling pipe for pipe breakage • Check maintenance hole • Sampling pipe not correctly fitted • Junctions open (fittings, flexible transitions) • Check and clean LS sensor
004	Invalid LS-Ü parameters	Sampling pipe	<ul style="list-style-type: none"> • Outside of range (working point) • Check and clean LS sensor • LS sensor defective → replace
008	Air flow sensor defective / missing	Air flow sensor Connection line	<ul style="list-style-type: none"> • Not fitted, not mounted • Connection line defective • LS sensor defective → replace
G50, fan faults			
Code	Meaning	Check:	Possible causes and remedy:
001	Tacho signal missing	Check fan terminals (white wire)	<ul style="list-style-type: none"> • Poor connection • Fan defective • AMB defective → replace
002	Motor regulation outside range	Check ASD operating voltage, Check fan connection	<ul style="list-style-type: none"> • Set operating voltage correctly • Fan defective → replace • AMB defective → replace
004	Motor current too low	Fan unit, fan connection	<ul style="list-style-type: none"> • Fan mechanically blocked • Fan defective → replace • AMB defective → replace
G60, initial reset faults			
Code	Meaning	Check:	Possible causes and remedy:
004	Initial reset time-out	Motor run-in time	<ul style="list-style-type: none"> • Failure to observe waiting time before initial reset • Carry out new initial reset
008	Invalid parameters for initial reset	Sampling pipe specifications	<ul style="list-style-type: none"> • Observe sampling pipe specifications • Initial reset was interrupted (by "ASD Off") → new initial reset

→→

Continuation:

G70, RIM 1 faults			
Code	Meaning	Check:	Possible causes and remedy:
001	Fault RIM 1	Ribbon cable connection Module	<ul style="list-style-type: none"> • Ribbon cable incorrectly attached or defective → check, replace. • Module removed and not logged off. • Module defective → replace
064	Incompatible RIM fault	Note the production version, should be greater than 181214	<ul style="list-style-type: none"> • Replace RIM
128	RIM fault, too many RIMs	Number of RIMs	<ul style="list-style-type: none"> • Only 1 RIM permitted!
G71, XLM faults			
Code	Meaning	Check:	Possible causes and remedy:
016	XLM fault	Ribbon cable connection Module	<ul style="list-style-type: none"> • Ribbon cable incorrectly attached or defective → check, replace. • Module removed and not logged off. • Module defective → replace
064	XLM fault, too many XLMs	Number of XLMs	<ul style="list-style-type: none"> • Only 1 XLM permitted!
G73, SD memory card			
Code	Meaning	Check:	Possible causes and remedy:
001	SD memory card fault, missing or defective	SD memory card	<ul style="list-style-type: none"> • SD memory card was removed without logging off • SD memory card defective → replace
G80, AMB faults			
Code	Meaning	Check:	Possible causes and remedy:
004	Undervoltage fault	Operating voltage < 13 VDC Conductor cross-section	<ul style="list-style-type: none"> • Conductor cross-section too weak → must be enlarged. • Voltage of the power supply not OK → check and correct if needed
008	Clock fault	Lithium battery Clock setting	<ul style="list-style-type: none"> • Isolation strip still present on the lithium battery → remove. • Clock is not set • Lithium battery defective → replace
G81, Operating system faults			
Code	Meaning	Check:	Possible causes and remedy:
all	See Sec. 8.5.4.3	FW / AMB	<ul style="list-style-type: none"> • HW reset • FW upgrade • AMB defective → replace

11 Options

11.1 Sampling pipe

If the sampling pipe is being used in extremely corrosive environments, provide for sufficiently resistant tube materials. Please contact the manufacturer of the ASD 531 for the material specifications.



Notices

- Tube materials other than those listed in Sec. 5.3 may be used only after consulting with the manufacturer of the ASD 531 and with his written consent.
- Only use tubes (material, supplier, dimensions) which have been tested and approved by the manufacturer of the ASD 531 (see also Sec. 5.3).

11.2 Use under extreme conditions

Applications with extremely high levels of dust and/or dirt, extreme temperature ranges and/or atmospheric humidity outside the specified limit values require the use of accessory parts as instructed by the manufacturer, e.g.:

- Filter-box/dust filter unit;
- Dirt trap box;
- Dust retaining box;
- Water retaining box;
- Manual ball valve for sporadic cleaning of the sampling pipe using compressed air;
- Automatic blow-out device;
- Insulation of the sampling pipe;
- Use of cooling sections in the sampling pipe



Notices

- Operation and application under extreme conditions may be implemented only after consulting with the manufacturer and under his supervision.
- The use of the aforementioned accessory parts is subject to a sampling pipe calculation using "ASD Pipe-Flow" (exceptions, see Sec. 4.3.2).
- The initial reset during commissioning must be carried out with the accessory parts required for operation under extreme conditions.
- If an additional unit is retrofitted to an ASD 531 already installed, a new initial reset must be carried out.

11.3 Use of detector boxes

Additional detector boxes (e.g. REK 511) may have to be used in the sampling pipe to create detection areas (e.g. horizontal localisation). The applicable country-specific guidelines must be observed (e.g. DIN VDE 0833-2 in Germany, Cantonal Fire Insurance Union in Switzerland). For more information on the REK 511 detector box, please refer to the separate data sheet (T 135 422).



Notices

- The REK 511 detector box cannot be operated from the ASD 531. The REK 511 detector box has to be connected directly from the FACP using an appropriate addressing module.
- When using detector boxes, it may be necessary to carry out a sampling pipe calculation using "ASD PipeFlow" (see Sec. 4.3.2).

12 Article numbers and spare parts

12.1 Detector housings and accessories

Designation	Article no.
Aspirating Smoke Detector ASD 531	11-2000002-01-XX
Replacement smoke sensor SSD 31; 0.02%/m to 10%/m	11-2200009-01-XX
eXtended Line Module XLM 35 incl. mounting set	11-2200003-01-XX
RIM 36 Relay Interface Module incl. mounting set	11-2200005-01-XX
SD memory card (industrial version)	11-4000007-01-XX
Printed circuit board AMB 31 main board	11-2200012-01-XX
Aspirating Fan Unit AFU 32, complete	11-2200008-01-XX
Air Flow Sensor AFS 32	11-2200007-01-XX
Insect Protection Screen IPS 35 (set of 2)	11-2300012-01-XX
Lithium battery	11-4000002-01-XX
Cable screw union M20 (set of 10)	11-4000003-01-XX
Cable screw union M25 (set of 10)	11-4000004-01-XX
Adapters for US cable screw unions AD US M-Inch	11-2300029-01-XX
UMS 35 Universal Module Support	4301252.0101

12.2 Sampling pipe and accessories

The article numbers of all the available parts for the sampling pipe (tubes, fittings, etc.) are listed in a separate document (T 131 194).

13 Technical data

Type	ASD 531		
Supply voltage range	14 to 30 (UL/FM = 16.4 to 27)		VDC
Maximum power consumption, measured at →	14 VDC ①	typical 24 VDC	
ASD 531	Quiescent / fault	approx. 110	approx. 75 mA
	Alarm	approx. 120	approx. 80 mA
	additionally with RIM 36	approx. 25	approx. 15 mA
	additionally with XLM 35	approx. 10	approx. 5 mA
Switch-on current peak ② (caused by EMC protection elements on the ASD supply input)			approx. 5 A for max. 1 ms
Sampling pipe length	see Sec. 4.2.1		
Sampling pipe diam., typical (inner/outer)	Ø 20 / 25 mm		
Max. number of sampling holes	see Sec. 4.2.1		
Sampling hole diameter	Ø 2 / 2.5 / 3 / 3.5 / 4 / 4.5 / 5 / 5.5 / 6 / 6.5 / 7 mm		
Response range	EN 54-20, Class A, B, C		
Protection type compliant with IEC 529 / EN 60529	54		IP
Ambient conditions compliant with IEC 721-3-3 / EN 60721-3-3	3K5 / 3Z1		class
Extended ambient conditions:			
• Detector housing temperature range	-10 – +55 (UL max. +40)		°C
• Sampling pipe temperature range	-10 – +55 ③		°C
• Max. permissible temperature fluctuation in detector housing and sampling pipe operation	20 ③		°C
• Max. permissible storage temperature for detector housing (without condensation)	-30 – +70		°C
• Ambient pressure difference between detector housing and sampling pipe (sampling holes)	must be identical		
• Humidity ambient condition for detector housing (transient without condensation)	95 ③		% rel. h
• Humidity ambient condition (continuous)	70 ③		% rel. h
Max. loading capacity, relay contact	50 (UL max. 30)		VDC
	1		A
	30		W
Max. loading capacity per OC output (dielectric strength 30 VDC)	100		mA
Plug-in terminals	2.5 mm ²		
Cable entry for cable Ø	Ø 5 – 12 (M20) / Ø 9 – 18 (M25) mm		
Sound pressure level	25 dB (A) / 1 m		
Housing material	ABS blend, UL 94-V0		
Housing colour	grey 280 70 05 / anthracite violet 300 20 05		RAL
Approvals	EN 54-20 / EN 54-27 / FM 3230-3250 / UL 268 / UL 268A / ULC-S529		
ASD 531-1 dimensions (W x H x D)	195 x 333 x 140		mm
Weight ASD 531-1	1,950		g



Notices

- ① Power consumption at maximum permitted voltage drop in the electrical installation (decisive value for calculating the conductor cross-section).
- ② May cause the protective circuit to trigger immediately in the case of power supplies with overload protective circuits (primarily in devices with no emergency power supply and output current of < 1.5 A).
- ③ Lower or higher temperature ranges are also possible subject to consultation with the manufacturer. The manufacturer must be consulted if the device is used in the condensation range.

14 List of figures

Fig. 1 General operating principle	15
Fig. 2 Block diagram	16
Fig. 3 Workflow for project-related programming.....	18
Fig. 4 Mechanical design	26
Fig. 5 Electrical design	28
Fig. 6 "ASD PipeFlow" program interface.....	32
Fig. 7 Examples of planning with "ASD PipeFlow" calculation.....	35
Fig. 8 Examples of planning without "ASD PipeFlow" calculation.....	35
Fig. 9 Sampling pipe definitions	36
Fig. 10 Size of sampling holes	37
Fig. 11 Equipment monitoring layout variants (examples).....	40
Fig. 12 Monitoring air-conditioning and ventilation ducts in compliance with EN 54-27	41
Fig. 13 Air recirculation for differing climate zones	41
Fig. 14 Workflow for project-specific programming and adjustment	42
Fig. 15 Detector housing dimensioned drawing and drilling plan.....	47
Fig. 16 Open, closing and securing the detector housing.....	50
Fig. 17 Mounting position and pipe entries on the detector housing.....	51
Fig. 18 Removing the air outlet pipe plug.....	52
Fig. 19 Turning the labelling strips	52
Fig. 20 Cutting the tubes	55
Fig. 21 Assembling the tubes	55
Fig. 22 Vertical sampling pipe	55
Fig. 23 90° bend, branching point	55
Fig. 24 Screw-free fastening of a sampling fixture.....	56
Fig. 25 Transition from fittings to flexible tube	57
Fig. 26 Creating the sampling holes.....	58
Fig. 27 Mounting clips	58
Fig. 28 Using sampling funnels	58
Fig. 29 Mounting the ceiling bushing.....	59
Fig. 30 Mounting accessory parts	60
Fig. 31 Deploying the smoke sensors	62
Fig. 32 Installing additional modules	63
Fig. 33 Types of power supply	66
Fig. 34 Reset input.....	66
Fig. 35 Control via supply with relay.....	67
Fig. 36 Control via the "Reset external" input.....	68
Fig. 37 Connection to zone detection.....	69
Fig. 38 Connection on selective identification or addressable loop	69
Fig. 39 Connection from XLM 35.....	70
Fig. 40 Connecting the OC outputs.....	70
Fig. 41 Detector housing opened for commissioning.....	71
Fig. 42 Control and indicator elements on the AMB 31	72
Fig. 43 Commissioning workflow.....	74
Fig. 44 Airflow tolerance.....	80
Fig. 45 View of the operation and display elements	85
Fig. 46 XLM 35 operation and display.....	91
Fig. 47 Removing the aspirating fan unit.....	95
Fig. 48 Removing the air flow sensors	96

Document history

First edition Date 15.10.2015

Index “a” Date 31.10.2016

Most important changes compared with previous issue:

Section / Fig.		New (n) / changed (c) / deleted (d)	What / Reason
1.1	c	Modification of the device configuration from FACP (operability via XLM 35), text removed	Correction
1.8	n	Reference to new Sec. 4.12, use for UL	New UL use
2.2.12.1 / 2.2.17 / 7.8 / 8.3 / 8.5.2 / 8.5.4.2 / 8.5.4.3 / 9.1 / 9.3.1 / 10.3.1	n / c	New “Filter monitoring” function: <ul style="list-style-type: none"> • configuration options • new switch positions 8 and 9 at rotary switch “Mode” • new Sec. “Filter monitoring operation” • new event group G16 with event code 001 and 016 • maintenance on dust filter units • new Sec. “Filter replacement for dust filter units” • description of the fault conditions 	Extension
2.2.1 / 6.5.1	n	Supply voltage range for UL specified	New UL use
4.2.2	n	New section, Usable accessory materials for the sampling pipe	Addition
4.4.4.1	c	Rotary switch “Holes”, B = 11 deleted	Correction
4.6 / Fig. 12 / 7.3.6	n	New section, Monitoring of air-conditioning and ventilation ducts compliant with EN 54-27	Addition
4.9.1 / 6.5	n	Notice supplemented: do not use looped wire	New UL use
4.9.2	c	Notice: support terminals only for power supply line	New UL use
4.12	n	New section, use for UL	New UL use
6.2	n	Notice supplemented: for UL, replacement of the screw-junction pieces with AD US M-Inch adapter	New UL use
6.4 / 6.6.4.3	n	Notice about “EN 54-17” identification sign	Addition
6.6	c	Text correction “country-specific e.g. EN 54-4”	Correction
6.6.2 / Fig. 34	c	Terminal designation “reset input” corrected	Correction
6.6.4.3	c	Number of XLM on addressable loop	Correction
8.1 / 8.5.1	c	Lamp test	Addition, Correction
8.5.4.2	c	Event group G03 removed / “Alarm 2” text removed, supplement G14	Correction (text error)
8.5.4.3	c	Event group G03 removed / correction of the event texts for G81 / inclusion under “Fault conditions”	Correction (text error) / expansion
12.1	n	New accessory: AD US M-Inch	New UL use
13	n	Note about UL use concerning supply voltage range, temperature range, relay contact, approvals	New UL use

Index "b" Date 30.04.2018

Most important changes compared with previous issue:

Section / Fig.		New (n) / changed (c) / deleted (d)	What / Reason
2.2.6 / 6.5.3	c	Text corrections ("Sampling tube" → "Sampling pipe")	Correction
2.2.6 / 8.5.4.3 / 10.3.1	c	Text "Smoke sensor" removed, since here not necessary	Correction
2.2.6 / 6.5.3 / 7.2 / 7.2.1.3	n	RIM 36 alternative relay assignment via DIP switch "Relay" no. 4	Extension
2.2.11 / 2.2.13	c	Fault triggering "Dust" only via RIM 36	Supplemental text, correction
2.2.17 / 7.8	c	Section described better ("Filter monitoring" instead of "Filter function"; the term "workdays" and the prerequisite "time" defined)	Supplemental text, correction
4.2.2 / 4.3.2 / 5.5.12 / Fig. 30	n	Dust filter unit DFU 911 integrated	Extension
4.4.4.1 / 7.2 / 7.3.2	c	Extended switch position „Class“ D – F , without dust filter	Erweiterung
4.9.1 / 4.9.2	c	UL use: text "looped lines" and "support terminals" defined better	Supplemental text
4.10 / 13	c	"Sound pressure level" instead of "noise level", value specification corrected	Correction
6.6.5	c	OC outputs short-circuit-proof	Supplemental text, correction
10.1	c	Procedure for defective units / replacement material	Supplemental text, correction